

Models Thermospan[®], 200- 20, 200, 150, 125

TORSION

COMMERCIAL
STANDARD LIFT

INSTALLATION INSTRUCTIONS AND OWNER'S MANUAL

If you need assistance, please call 1-866-569-3799 (press Option 1) and follow the prompts to contact a customer service representative. They will be happy to handle any questions that you may have.

Table Of Contents

Pre-Installation	2
Important Safety Instructions	2
Removing an Existing Door and Preparing the Opening	2
Package Contents	4
Door Section Identification	5
Tools Required	6
Breakdown Of Parts	7
Door Installation Instructions	8
Counterbalance Installation Instructions	17
Optional Installation	25
Door Arm Hookup	25
Inside Lock	25
Lock Bar	25
Step Plate	27
Pull Down Rope	27
Exhaust Port	27
Chain Hoist	28
Pusher Springs	28
Maintenance	30
Cleaning Your Garage Door	30
Painting Your Garage Door	30
Operation And Maintenance	30
Warranty	32

IMPORTANT NOTICES!

To avoid possible injury, read and fully understand the enclosed instructions carefully before installing and operating the garage door. Pay close attention to all warnings and notes. After installation is complete, fasten this manual near garage door for easy reference.

This Installation document is available at no charge from:

- Your local Wayne Dalton Sales Center, or
- Online at www.Wayne-Dalton.com, or
- By mailing to: Wayne Dalton, a division of Overhead Door Corporation, P.O. Box 67, Mt. Hope, OH., 44660

Important Safety Instructions

DEFINITION OF KEY WORDS USED IN THIS MANUAL:

WARNING

INDICATES A POTENTIALLY HAZARDOUS SITUATION WHICH; IF NOT AVOIDED, COULD RESULT IN SEVERE OR FATAL INJURY.

CAUTION

PROPERTY DAMAGE OR INJURY CAN RESULT FROM FAILURE TO FOLLOW INSTRUCTIONS.

IMPORTANT: REQUIRED STEP FOR SAFE AND PROPER DOOR OPERATION.

NOTE: Information assuring proper installation of the door.

READ THESE INSTRUCTIONS CAREFULLY BEFORE ATTEMPTING INSTALLATION. IF IN QUESTION ABOUT ANY OF THE PROCEDURES, DO NOT PERFORM THE WORK. INSTEAD, HAVE A TRAINED DOOR SYSTEMS TECHNICIAN DO THE INSTALLATION OR REPAIRS.

1. READ AND FOLLOW ALL INSTALLATION INSTRUCTIONS.
2. Wear protective gloves during installation to avoid possible cuts from sharp metal edges.
3. It is always recommended to wear eye protection when using tools, otherwise eye injury could result.
4. Avoid installing your new door on windy days. Door could fall during the installation causing severe or fatal injury.
5. Doors 12'-0" wide and over should be installed by two persons, to avoid possible injury.
6. Operate door only when it is properly adjusted and free from obstructions.
7. If a door becomes hard to operate, inoperative or is damaged, immediately have necessary adjustments and/ or repairs made by a trained door system technician using proper tools and instructions.
8. DO NOT stand or walk under a moving door, or permit anybody to stand or walk under an electrically operated door.
9. DO NOT place fingers or hands into open section joints when closing a door. Use lift handles/ gripping points when operating door manually.
10. DO NOT permit children to operate garage door or door controls. Severe or fatal injury could result should the child become entrapped between the door and the floor.
11. Due to constant extreme spring tension, do not attempt any adjustment, repair or alteration to any part of the door, especially to springs, spring brackets, bottom corner brackets, fasteners, counterbalance lift cables or supports. To avoid possible severe or fatal injury, have any such work performed by a trained door systems technician using proper tools and instructions.
12. On electrically operated doors, pull down ropes must be removed and locks must be removed or made inoperative in the open (unlocked) position.
13. Top section of door may need to be reinforced when attaching an electric opener. Check door and/ or opener manufacturer's instructions.
14. Visually inspect door and hardware monthly for worn and or broken parts. Check to ensure door operates freely.
15. Test electric opener's safety features monthly, following opener manufacturer's instructions.
16. NEVER hang tools, bicycles, hoses, clothing or anything else from horizontal tracks. Track systems are not intended or designed to support extra weight.
17. This door may not meet the building code wind load requirements in your area. For your safety, you will need to check with your local building official for wind load code requirements and building permit information.
18. For windloaded doors, the wind performance is achieved via the entire door system and component substitution is not authorized without express permission by Wayne Dalton.
19. For door heights greater than 10 feet or a door balance weight greater than 400 pounds, Chain Hoist or Motor Operator is recommended.

NOTE: It is recommended that 5/16" lag screws are pilot drilled using a 3/16" drill bit, prior to fastening.

CAUTION

IF ANY PART OF THE DOOR IS TO BE INSTALLED ONTO PRESERVATIVE-TREATED WOOD, PTFE-COATED OR STAINLESS STEEL FASTENERS MUST BE OBTAINED AND USED. REPLACEMENT FASTENERS MUST BE OF AT LEAST EQUAL STRENGTH AND SIZE AS ORIGINAL FASTENERS. IF THE ORIGINAL FASTENER WAS RED-HEAD, THE REPLACEMENT FASTENER MUST BE RED-HEAD ALSO. CONTACT WAYNE DALTON FOR FASTENER STRENGTH VALUES IF NEEDED.

WARNING

IMPACT GUNS ARE NOT RECOMMENDED. WHEN INSTALLING 5/16" LAG SCREWS USING AN ELECTRIC DRILL/ DRIVER, THE DRILL/ DRIVERS CLUTCH MUST BE SET TO DELIVER NO MORE THAN 200 IN-LBS OF TORQUE. FASTENER FAILURE COULD OCCUR AT HIGHER SETTINGS.

IMPORTANT: RIGHT AND LEFT HAND IS DETERMINED INSIDE THE BUILDING LOOKING OUT.
MISSING IMAGE: M:/TYPEFI_FILESTORE/WAYNE DALTON TESTS/

Removing an Existing Door and Preparing the Opening

IMPORTANT: COUNTERBALANCE SPRING TENSION MUST ALWAYS BE RELEASED BEFORE ANY ATTEMPT IS MADE TO START REMOVING AN EXISTING DOOR.

WARNING

A POWERFUL SPRING RELEASING ITS ENERGY SUDDENLY CAN CAUSE SEVERE OR FATAL INJURY. TO AVOID INJURY, HAVE A TRAINED DOOR SYSTEMS TECHNICIAN, USING PROPER TOOLS AND INSTRUCTIONS, RELEASE THE SPRING TENSION.

To avoid possible injury and to insure proper installation, it's highly recommended that you read and fully understand the complete instructions on removing an Existing Door & Preparing the Opening. These are available for download at www.Wayne-Dalton.com or at your local Wayne Dalton Sales Center.

IMPORTANT: IF YOU JUST REMOVED YOUR EXISTING DOOR OR YOU ARE INSTALLING A NEW DOOR, COMPLETE ALL STEPS IN PREPARING THE OPENING.

To ensure secure mounting of track brackets, side and center brackets, or steel angles to new or retro-fit construction, it is recommended to follow the procedures outlined in DASMA technical data sheets #156, #161 and #164 at www.dasma.com.

The inside perimeter of your garage door opening should be framed with wood jamb and header material. The jambs and header must be securely fastened to sound framing members. It is recommended that 2" x 6" lumber be used. The jambs must be plumb and the header level. The jambs should extend a minimum of 12" (305 mm) above the top of the opening for Torsion counterbalance systems. For low headroom applications, the jambs should extend to the ceiling height.

Minimum side clearance required, from the opening to the wall, is 3-1/2" (89 mm), for 2" track.

Minimum side clearance required, from the opening to the wall, is 4-1/2" (114 mm), for 3" track.

IMPORTANT: CLOSELY INSPECT JAMBS, HEADER AND MOUNTING SURFACE. ANY WOOD FOUND NOT TO BE SOUND, MUST BE REPLACED.

For Torsion counterbalance systems, a suitable mounting surface (2" x 6") must be firmly attached to the wall, above the header at the center of the opening.

NOTE: Drill a 3/16" pilot hole in the mounting surface to avoid splitting the lumber. Do not attach the mounting surface with nails.

WEATHERSTRIPS (MAY NOT BE INCLUDED):

Depending on the size of your door, you may have to cut or trim the weatherstrips (if necessary) to properly fit into the header and jambs.

NOTE: If nailing product at 40°F or below, pre-drilling is required.

NOTE: Do not permanently attach weatherstrips to the header and jambs at this time.

For the header, align the weatherstrip 1/8" to 1/4" inside the header edge, and temporarily secure it to the header with equally spaced nails. Starting at either side of the jamb, fit the weatherstrip up tight against the temporarily attached weatherstrip in the header and 1/8" to 1/4" inside the jamb edge. Temporarily secure the weatherstrip with equally spaced nails. Repeat for other side. This will keep the bottom section from falling out of the opening during installation. Equally space nails approximately 12" to 18" apart.

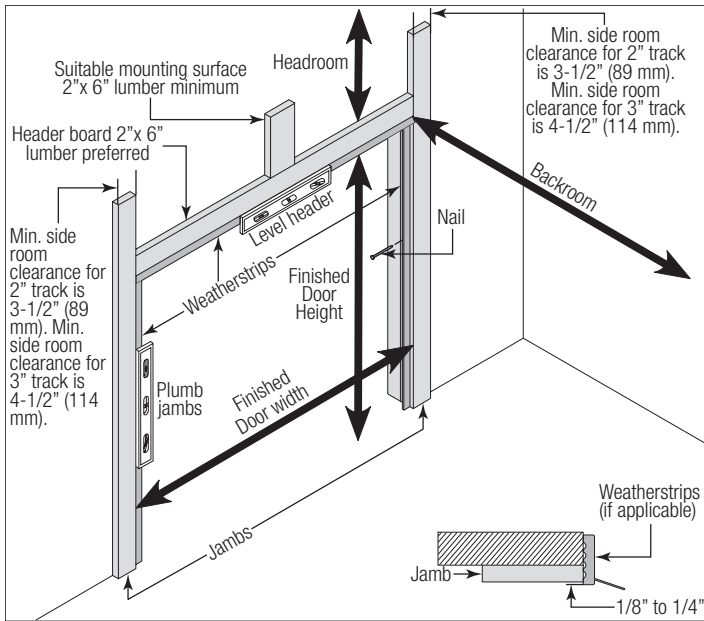

HEADROOM REQUIREMENT: Headroom is defined as the space needed above the top of the door for tracks, springs, etc. to allow the door to open properly. If the door is to be motor operated, 2-1/2" (64 mm) of additional headroom is required.

DIMENSION (DIM.) "Y": Indicates the distance from the header to the center line of torsion shaft.

NOTE: 2-1/2" of additional headroom is required for single trolley operator installations.

NOTE: Headroom can be reduced 2-1/2" by using the quick closing top fixture or by shortening the vertical tracks by 3" max.

HEADROOM REQUIREMENTS (MINIMUM DISTANCE REQUIRED)

Cable Drums	Dimensions	3" Track, 15" Radius	2" Track, 15" Radius	2" Track, 12" Radius
400-8, 400-12	Headroom Dim.	15-1/2"	14-1/2"	12-1/2"
5250-18		19"	18"	15"
800-32		21"	20"	17"

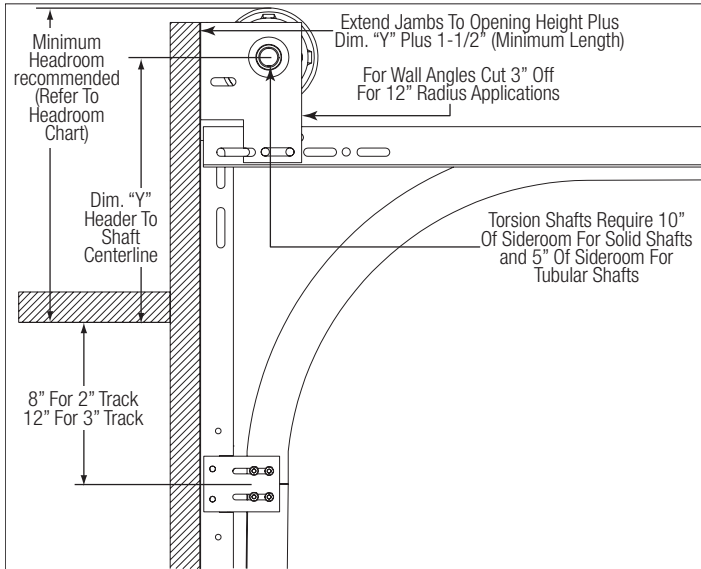

BACKROOM REQUIREMENT: Backroom is defined as the distance needed from the opening back into the garage to allow the door to open fully.

BACKROOM REQUIREMENTS (MINIMUM DISTANCE REQUIRED)

Track size	Manual Depth Into room	Dim. "A" Side room track		Dim. "B" Side room Torsion Shaft	
		Steel	Masonry / Wood	Solid	Tube
2"	Door Height Plus 18", Motor Plus 66"	2-1/2"	3-1/2"	10"	5"
3"	Door Height Plus 24", Motor Plus 66"	3"	5"	10"	5"

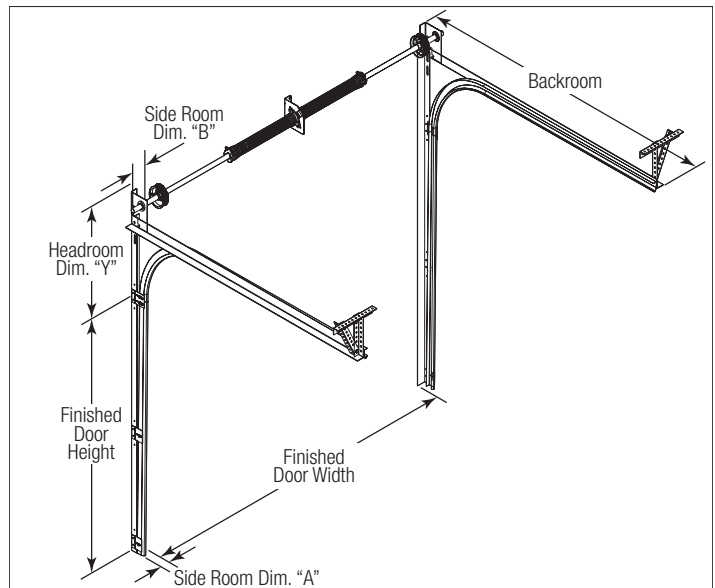

SIDE ROOM REQUIREMENTS: Side room is defined as the distance needed from the door opening to a wall or any obstruction.

SIDE ROOM REQUIREMENTS AND BACKROOM REQUIREMENTS (MINIMUM DISTANCE REQUIRED)

Track size	Depth Into Room	Dim. "A" Side room track		Dim. "B" Side room Torsion Shaft	
		Steel	* Masonry / Wood	Steel	* Masonry / Wood
2"	Door Height Plus 18"	3-1/2"	4"	10"	5"
3"	Door Height Plus 24"	4"	5"	10"	5"

NOTE: If your door is to have an operator, then the Depth Into The Room would be, Door Height Plus 50" for 2" track, Door Height Plus 56" for 3" track.

***NOTE:** Dimensions shown are for "No Overlap". For a 1" overlap condition, add 1" to Dimensions.

NOTE: Dimensions are for approximate bottom of track location only. Contact Wayne Dalton for job-specific clearance requirements when dealing with obstructions

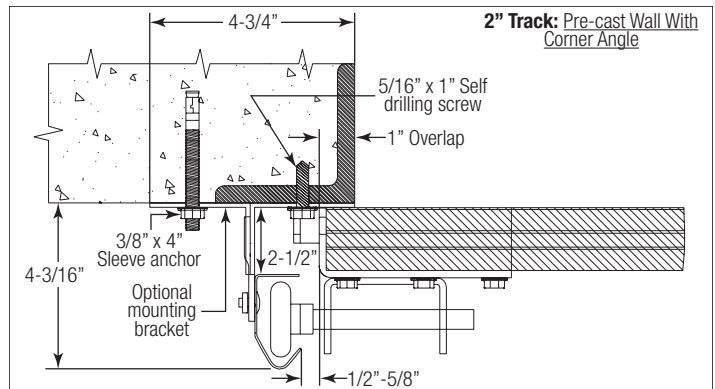

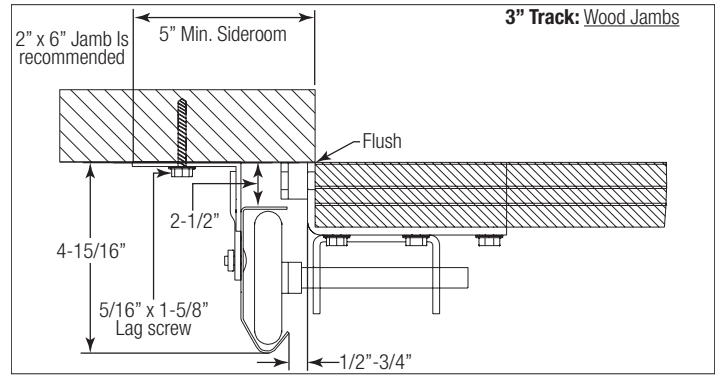
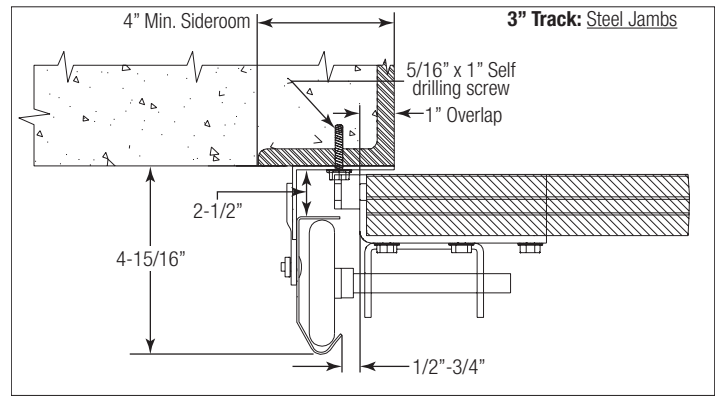
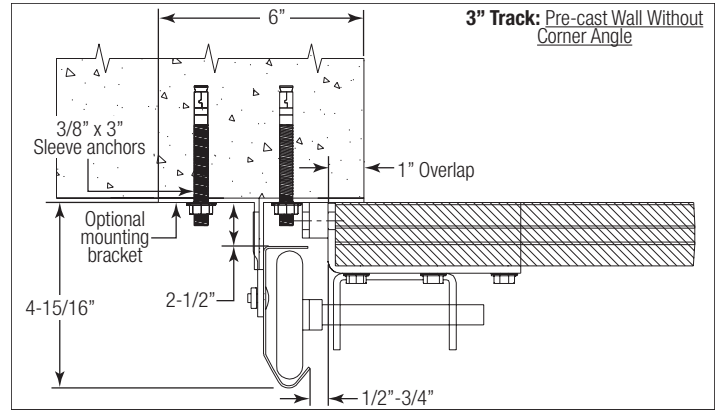
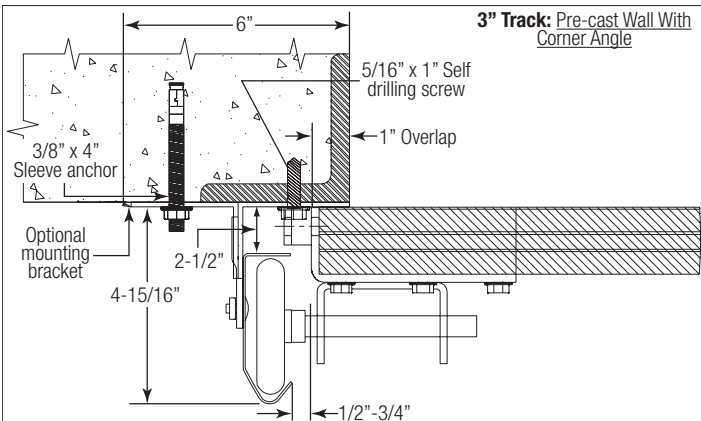
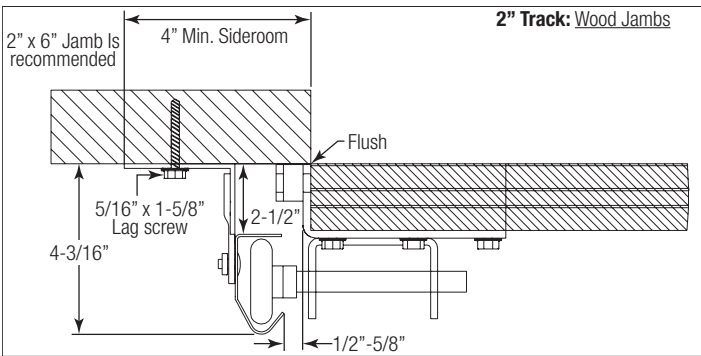
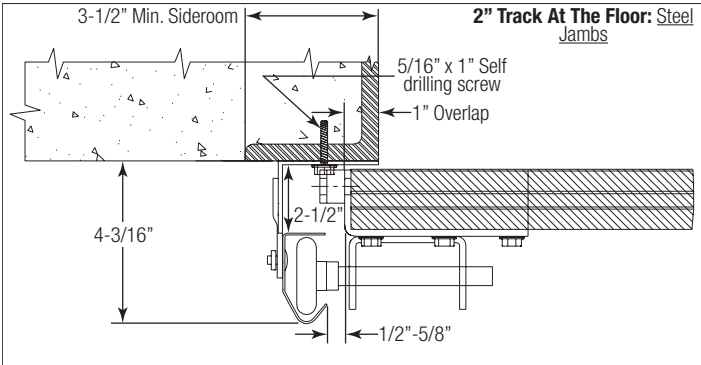
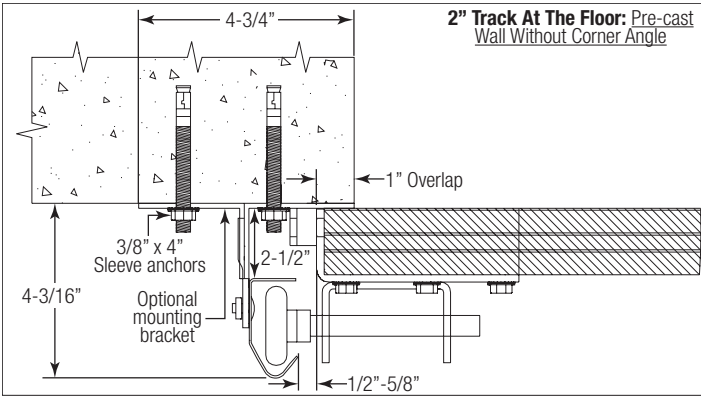

Package Contents

NOTE: Depending on the door model, some parts listed will not be supplied if not required. Rear Back Hangs may not be included with your door.

· ·	· ·
· ·	· ·
Door sections (as required)	
Torsion shaft / Torsion keyed shaft (as required)	
Torsion keyed shafts (as required)	

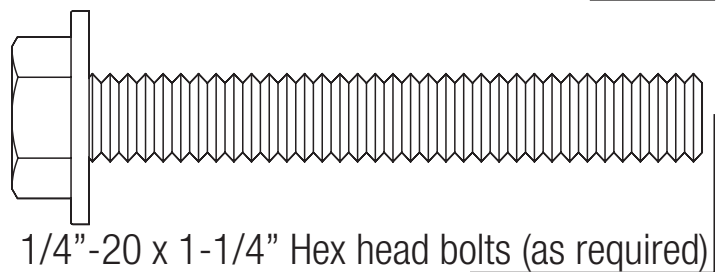
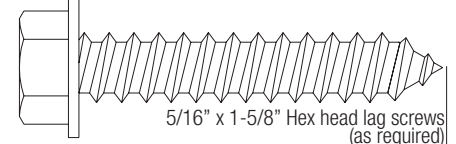
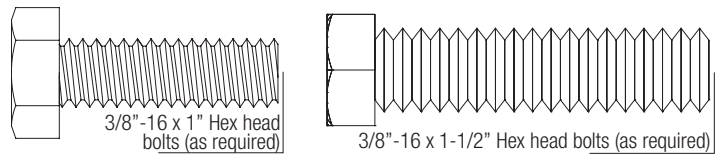
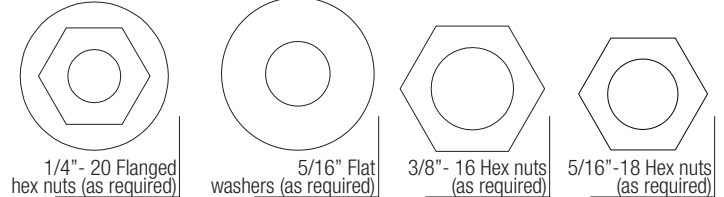
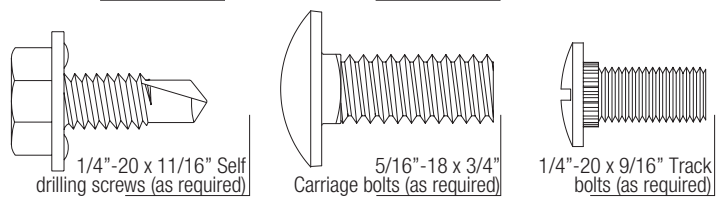
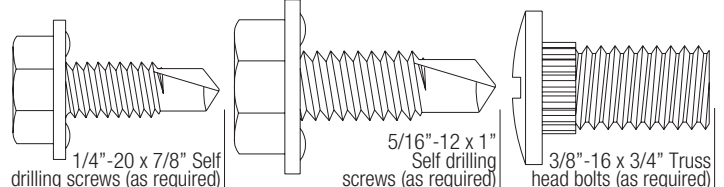
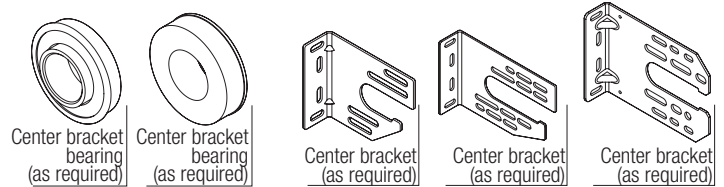
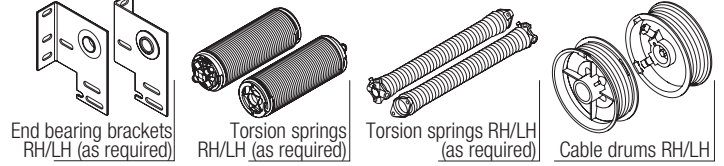
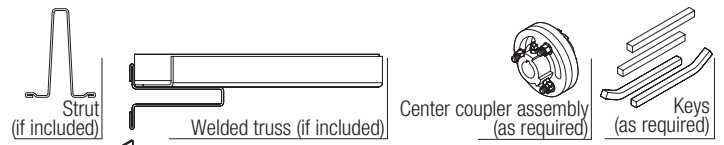
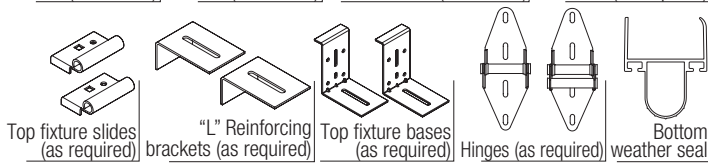
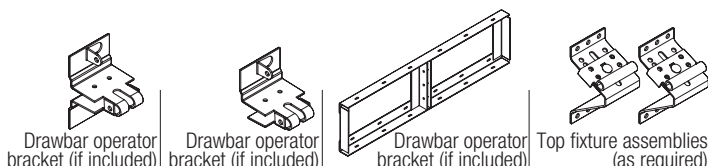
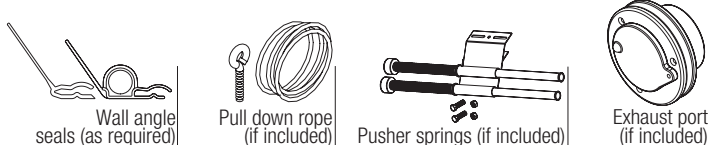
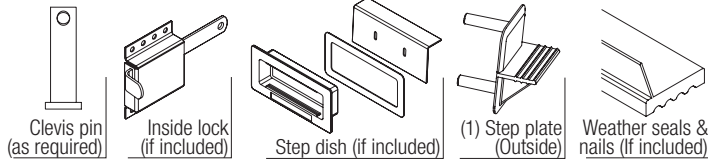
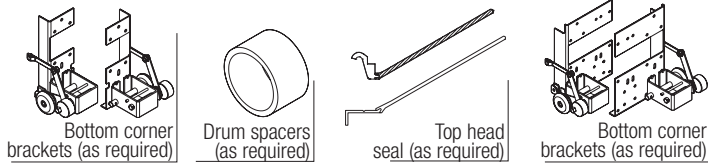
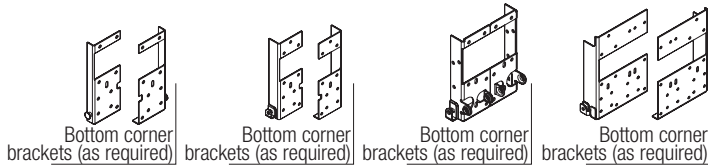
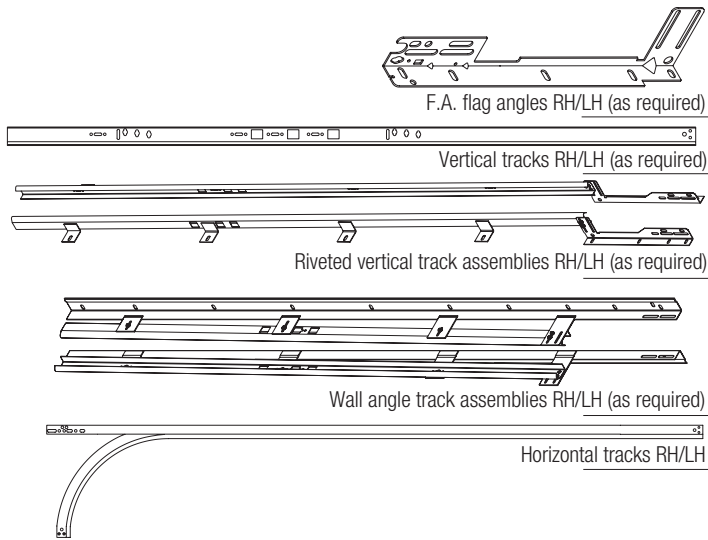

Door Section Identification

NOTE: To determine your Door Section Identification, refer to the Type Of Sections chart below to determine the number of sections your door came with.

Type Of Sections	
How Many Sections High	Type Of Section
12	Top Section
11	Intermediate Section IX (As Required)
10	Intermediate Section VIII (As Required)
9	Intermediate Section VII (As Required)
8	Intermediate Section VI (As Required)
7	Intermediate Section V (As Required)
6	Intermediate Section IV (As Required)
5	Intermediate Section III (As Required)
4	Intermediate Section II (As Required)
3	Intermediate Section I (As Required)
2	Lock Section
1	Bottom Section

When installing your door you must use sections of the appropriate height in the right stacking order. What sections heights you need to use in what order depends on the height of your door. Sections are either 24" or 21" in Section Height.

NOTE: If you have different sections heights, the 24" sections heights are always stacked at the bottom and the 21" sections height stacked to the top.

Unless your door is three sections height, you will not receive an Intermediate I section.

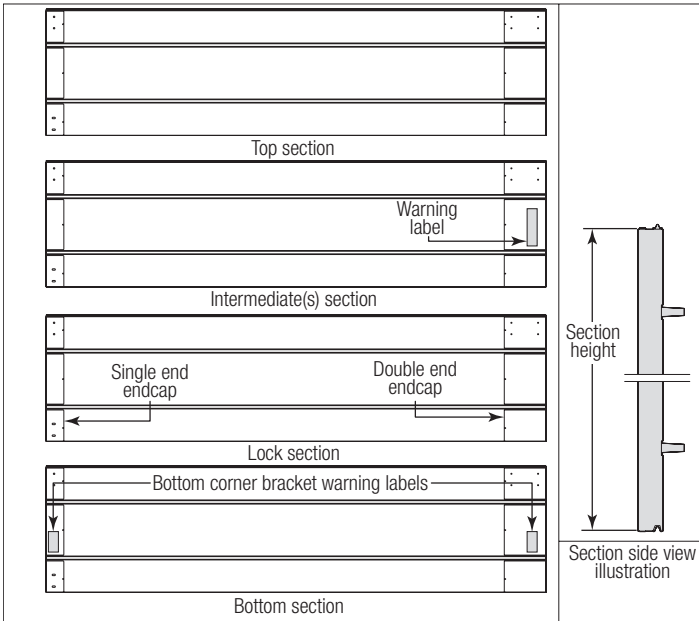

Tools Required

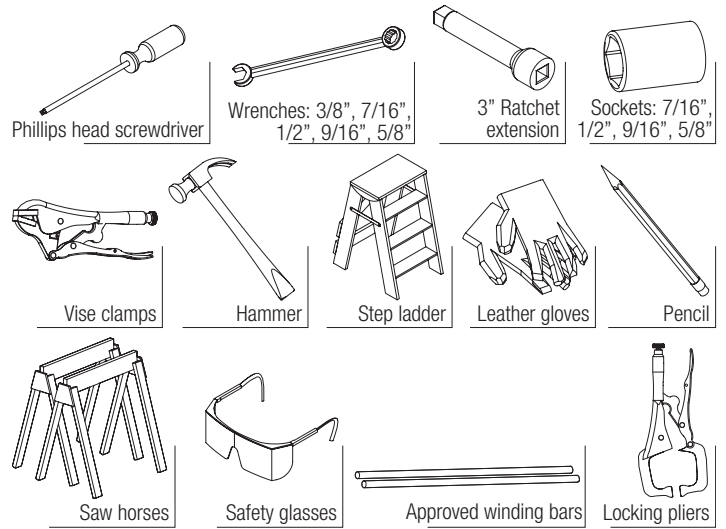
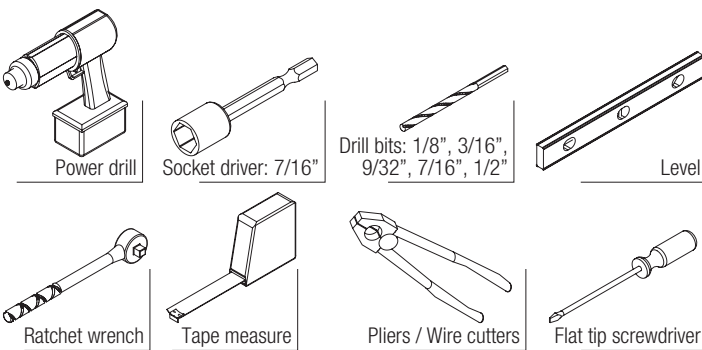

BREAKDOWN OF PARTS

NOTE: The illustrations shown on this page are general representations of the door parts. Each specific door model may have unique variations.

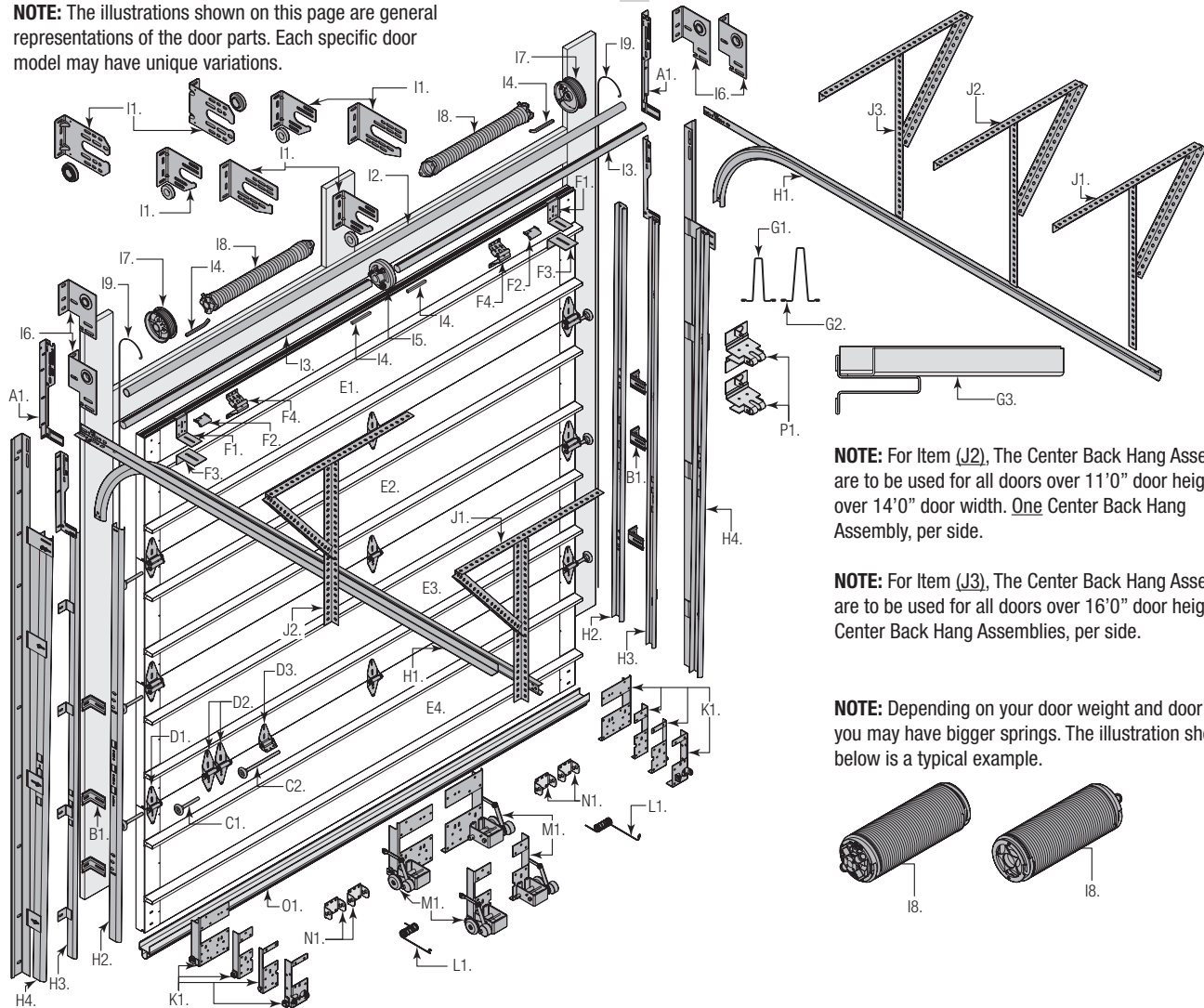

NOTE: For Item (J2), The Center Back Hang Assemblies are to be used for all doors over 11'0" door height and over 14'0" door width. One Center Back Hang Assembly, per side.

NOTE: For Item (J3), The Center Back Hang Assemblies are to be used for all doors over 16'0" door height. Two Center Back Hang Assemblies, per side.

NOTE: Depending on your door weight and door height, you may have bigger springs. The illustration shown below is a typical example.

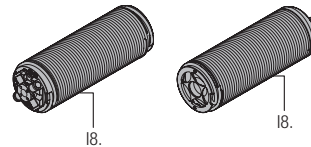

A. FLAG ANGLES (AS REQUIRED):

A1. Fully Adjustable (F.A.) Flag Angles

B. JAMB BRACKETS (AS REQUIRED):

B1. Fully Adjustable (F.A.) Jamb Brackets

C. TRACK ROLLERS (AS REQUIRED):

C1. Short Stem Track Rollers / C2. Long Stem Track Rollers

D. GRADUATED END HINGES:

D1. Single Graduated End Hinges (S.E.H.), Industry Standard
 D2. Double Graduated End Hinges (D.E.H.), Industry Standard
 D3. Half Center Hinges (As Required)

E. STACKED SECTIONS:

E1. Top Section / E2. Intermediate Section (s) / E3. Lock Section / E4. Bottom Section

F. TOP FIXTURES:

F1. Top Fixture Bases / F2. Top Fixture Slides
 F3. "L" Reinforcing Brackets (As Required)

G. STRUT(S) (AS REQUIRED):

G1. Strut (2" U-shaped) / G2. Strut (3" U-shaped)
 G3. Welded Trusses

H. TRACKS (AS REQUIRED):

H1. Left Hand and Right Hand Horizontal Track Assemblies
 H2. Left Hand and Right Hand Vertical Tracks
 H3. Left Hand and Right Hand Vertical Track Assemblies
 H4. Left Hand and Right Hand Wall Angle Track Assemblies

I. TORSION SPRING ASSEMBLY (AS REQUIRED):

I1. Center Bracket(s) With Center Bracket Bearing(s) (As Required)

I2. Torsion Shaft / Torsion Keyed Shaft (As Required)

I3. Torsion Keyed Shafts (As Required) / I4. Keys (As Required)

I5. Center Coupler Assembly (As Required)

I6. Left Hand And Right Hand End Bearing Brackets

I7. Left Hand And Right Hand Cable Drums

I8. Left Hand and Right Hand Torsion Springs (As Required)

I9. Counterbalance Lift Cables

J. REAR BACK HANGS:

J1. Left and Right Hand Rear Back Hangs Assemblies

J2. Left and Right Hand Rear Center Back Hang Assemblies (As Required)

J3. Left and Right Hand Rear Center Back Hang Assemblies (As Required)

K. BOTTOM CORNER BRACKETS (AS REQUIRED):

K1. Left Hand and Right Hand Bottom Corner Brackets

L. CABLE KEEPERS (AS REQUIRED):

L1. Cable Keepers

M. BROKEN CABLE SAFETY DEVICES (AS REQUIRED):

M1. Left Hand And Right Hand Broken Cable Safety Devices

N. TRACK ROLLER CARRIER'S (AS REQUIRED):

N1. Track Roller Carrier's

O. BOTTOM WEATHER SEAL:

O1. Bottom Weather Seal (Door Width)

P. DRAWBAR OPERATOR BRACKET (FOR TROLLEY OPERATED DOORS):

P1. Drawbar Operator Bracket (As Required)

DOOR INSTALLATION INSTRUCTIONS

Before installing your door, be certain that you have read and followed all of the instructions covered in the pre-installation section of this manual. Failure to do so may result in an improperly installed door.

NOTE: Reference TDS 160 for general garage door terminology at www.dasma.com.

IMPORTANT: IF THE DOOR WILL BE EXPOSED TO A SIGNIFICANT AMOUNT OF ROAD SALT, PAINT THE BARE GALVANIZED BOTTOM WEATHER STEEL RETAINER TO INHIBIT RUSTING.

1

Attaching Flag Angles and Jamb Brackets To Vertical Tracks

NOTE: If you have Riveted Track or Angle Mount Track, skip this step.

FOR DOORS WITH FULLY ADJUSTABLE TRACK: Hand tighten the left hand flag angle to the left hand vertical track using (2) 1/4" - 20 x 9/16" track bolts and (2) 1/4" - 20 flange hex nuts.

NOTE: The bottom jamb bracket is always the shortest bracket, while the center jamb bracket is the next tallest. If three jamb brackets per side are included with your door, you will have received a top jamb bracket, which is the tallest.

To attach the bottom jamb bracket, locate lower hole of the hole/ slot pattern of the 1st hole set on the vertical track. Align the slot in the jamb bracket with the lower hole of the hole/ slot pattern. Hand tighten jamb bracket using (1) 1/4" - 20 x 9/16" track bolt and (1) 1/4" - 20 flange hex nut.

Place the center jamb bracket over the lower hole of the hole/ slot pattern that is centered between the bottom jamb bracket and flag angle of the 2nd hole set. Hand tighten jamb bracket using (1) 1/4" - 20 x 9/16" track bolt and (1) 1/4" - 20 flange hex nut.

If a top jamb bracket was included, hand tighten it to vertical track using the lower hole of the hole/ slot pattern in the 3rd hole set and (1) 1/4" - 20 x 9/16" track bolt and (1) 1/4" - 20 flange hex nut.

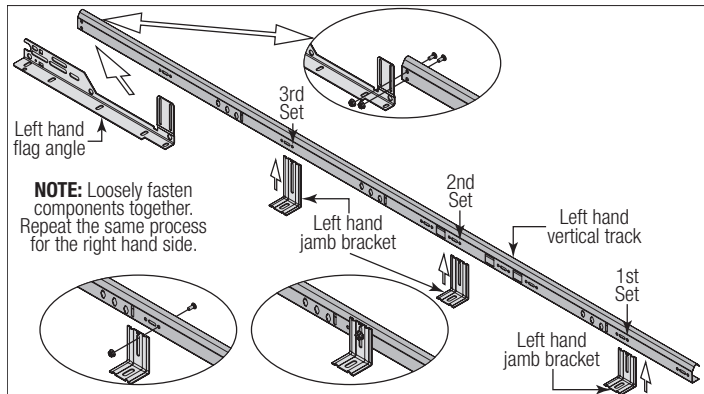

2

Attaching Bottom Weather Seal

NOTE: Refer to door section identification, located in the pre-installation section of this manual. Refer to Package Contents / Parts Breakdown, to determine your bottom section.

IMPORTANT: IF THE DOOR WILL BE EXPOSED TO A SIGNIFICANT AMOUNT OF ROAD SALT, PAINT THE BARE GALVANIZED BOTTOM WEATHER STEEL RETAINER TO INHIBIT RUSTING.

Position the bottom weather seal up against the bottom of the bottom section with the lip on the outside surface of the bottom section. Attach the bottom weather seal to the inside surface of the bottom section using one of the following scenarios listed below:

For door model Themospan® 125 and door width less than or equal to 18'4" uses 1/4" - 20 x 11/16" self drilling screws.

For door models Themospan® 150, 200 or 200-20 and door width less than or equal to 18'2" uses 1/4" - 20 x 11/16" self drilling screws.

For all Themospan® door models and door width greater than 18'2" uses 1/4" - 20 x 7/8" self drilling screws.

Placing one self drilling screw 6" in from each end of the bottom section and one self drilling screw every 18" (maximum) in between, as shown.

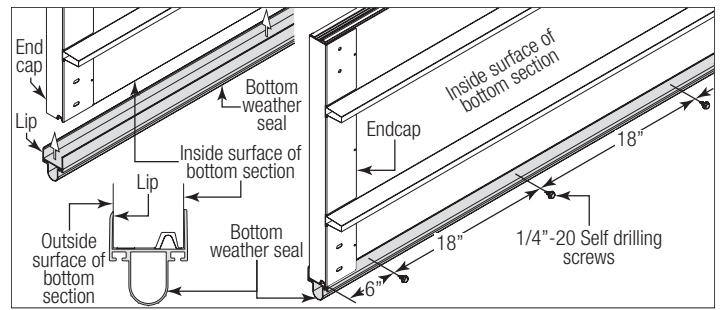

3

Attaching Bottom Corner Brackets

NOTE: Refer to door section identification, located in the pre-installation section of this manual or refer to Breakdown of Parts.

Uncoil the counterbalance lift cables.

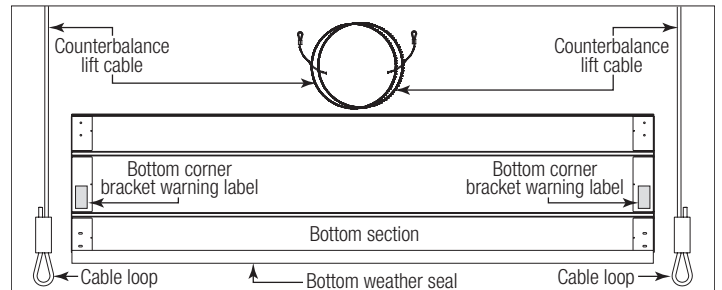

NOTE: Refer to Package Contents / Breakdown of Parts, to determine which bottom corner brackets you have.

NOTE: Depending on your door's configuration you may have to break the bottom corner brackets apart.

Depending on which bottom corner brackets you have (reference illustrations below), slip the loop at the ends of the counterbalance lift cable over the milford pin of the bottom corner bracket or secure the cable loop to the clevis pin and bottom corner bracket using a flat washer and a cotter pin. Repeat for other bottom corner bracket.

WARNING

ENSURE TIGHT FIT OF CABLE LOOP OVER PIN TO PREVENT COUNTERBALANCE LIFT CABLE FROM COMING OFF THE PIN, WHICH COULD ALLOW THE DOOR TO FALL AND RESULT IN SEVERE OR FATAL INJURY.

NOTE: Prior to installing the bottom corner brackets onto the bottom section, you may have to slit the bottom weather seal at both ends to allow the bottom corner brackets to be adhered to the bottom section unobstructed by the bottom weather seal.

IMPORTANT: DO NOT INSTALL BOTTOM CORNER BRACKETS OVER THE BOTTOM WEATHER SEAL.

Starting on the left hand side, attach the left hand bottom corner bracket to the left corner of the bottom section, making sure it is seated to the edges of the end cap, using the appropriate 1/4" - 20 self drilling screws using one of the following scenarios listed below:

For door model Themospan® 125 and door width less than or equal to 18'4" uses 1/4" - 20 x 11/16" self drilling screws.

For door models Themospan® 150, 200 or 200-20 and door width less than or equal to 18'2" uses 1/4" - 20 x 11/16" self drilling screws.

For all Themospan® door models and door width greater than 18'2" uses 1/4" - 20 x 7/8" self drilling screws.

NOTE: If you have broken cable safety devices, only install the appropriate top 1/4" - 20 self drilling screws to secure the bottom corner bracket to the bottom section. Reference Step Broken Cable Safety Devices.

NOTE: If you did not receive cable keepers or track roller carriers, then insert a short stem track roller with roller spacer (if applicable) into each of the bottom corner brackets, as shown.

NOTE: Verify that the bottom weather seal (bottom seal) is aligned with door section. If there is more than 1/2" excess bottom weather seal on either side, trim bottom weather seal even with door section.

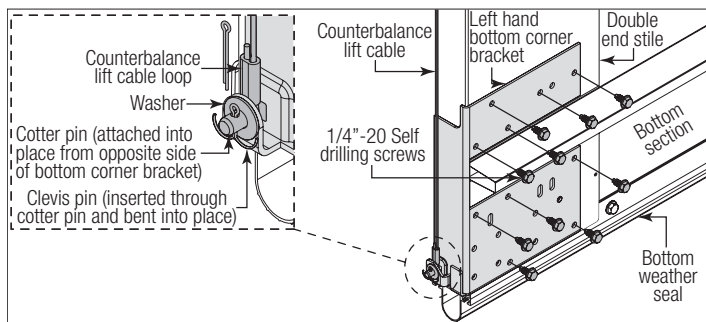
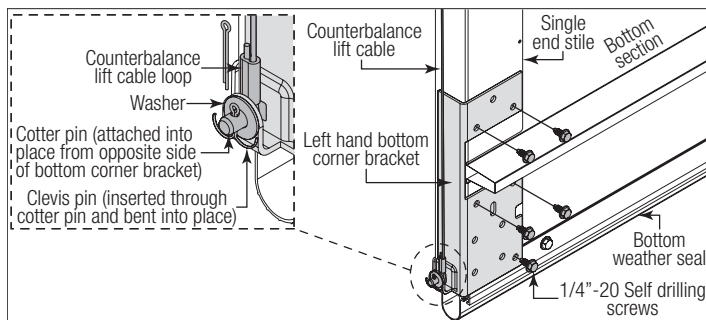
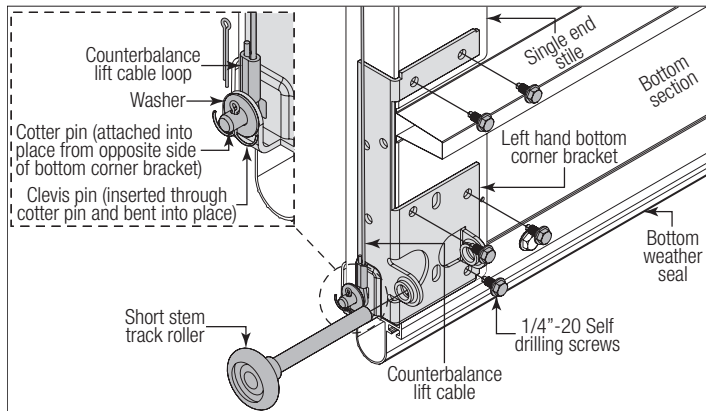
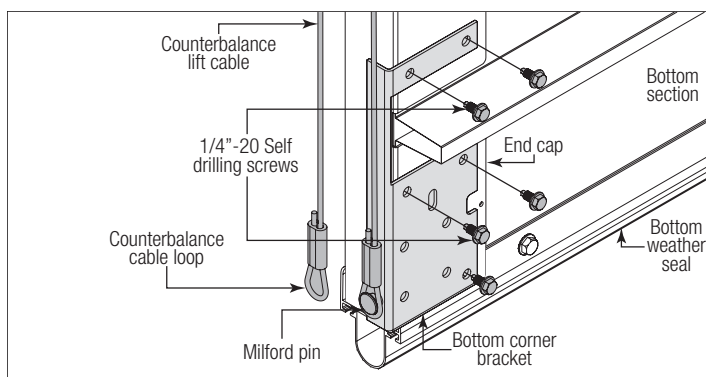

4 Attaching Track Roller Carrier's

NOTE: If you don't have track roller carriers, then skip this step. Refer to Package Contents / Breakdown of Parts, to determine if a track roller carrier was supplied with your door.

Starting on left hand side of the bottom section, attach the track roller carrier with the stamp orientated correctly to the bottom corner bracket by aligning the four holes of the track roller carrier with the four holes in the bottom corner bracket.

NOTE: For door model Thermospan® TS-125 only, orient the track roller carrier so that "TS 125" is facing is upward.

NOTE: For door models Thermospan® 150, 200 and 200-20, orient the track roller carrier so that "STD" is facing is upward.

Secure the track roller carrier to the bottom corner bracket using 1/4" - 20 x 7/8" self drilling screws, as shown. Repeat for the other track roller carrier(s). Using the illustration below, insert the appropriate stem track roller and roller spacer(s) into the correct inner / outer holes of the track roller carrier(s), as shown.

NOTE: For door model Thermospan® 125, the track roller carrier's outer holes are used on

both 2" track and 3" track applications with a short stem track roller.

NOTE: For door models Thermospan® 150, 200 and 200-20, the track roller carrier's inner holes are used on doors with 2" track applications with a short stem track roller; the outer holes are used on doors with 3" track applications with a long stem track roller.

Repeat the same process for the right hand side.

NOTE: If you received Cable Keepers, don't insert the short / long stem track roller and the roller spacer(s) into the track roller carrier.

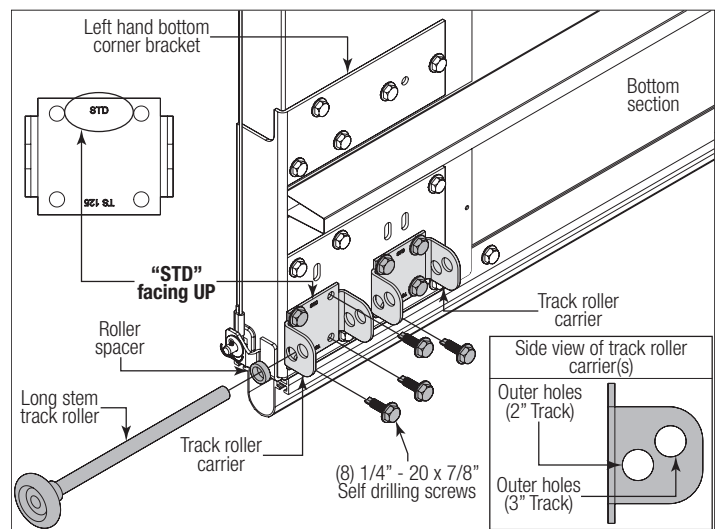
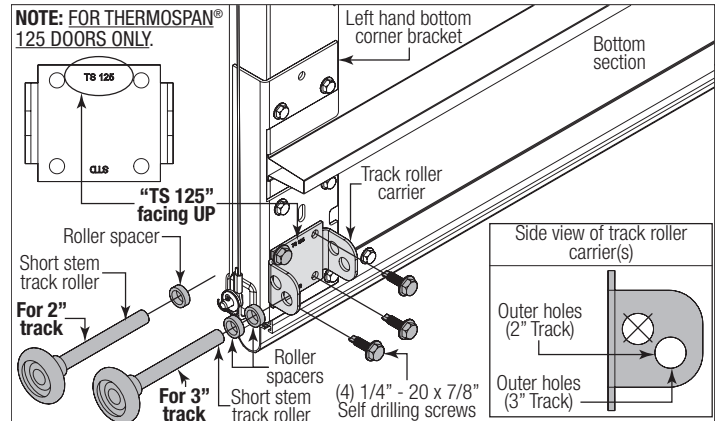

5 Attaching Cable Keepers

NOTE: If you don't have cable keepers, then skip this step. Refer to Package Contents / Breakdown of Parts, to determine if you have cable keepers.

IMPORTANT: CABLE KEEPERS ARE INTENDED TO HELP PREVENT COUNTERBALANCE LIFT CABLES FROM COMING OFF CABLE DRUMS ON MANUALLY OPERATED DOORS.

NOTE: Cable keepers are right hand and left hand.

NOTE: Cable keepers are color coded, black for right hand side and red for left hand side.

Locate the left hand cable keeper. Starting on the left hand side of bottom section, position the left hand cable keeper in between the roller carrier tabs. Insert a short stem track roller with roller spacer through the holes in the tabs and through the cable keeper. Repeat the same process for the right hand side.

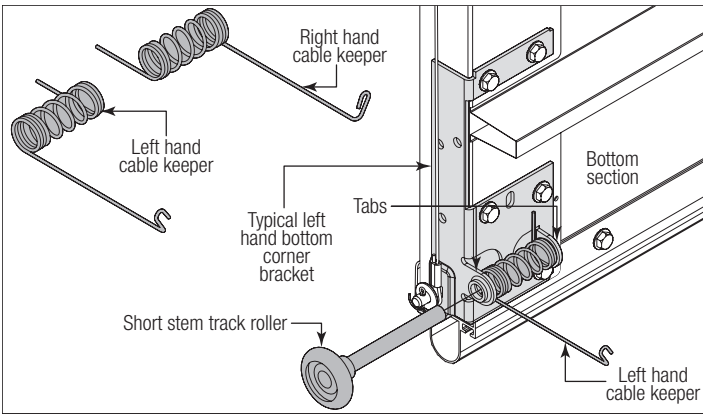

6 Attaching Broken Cable Safety Device

NOTE: If you don't have broken cable safety devices, then skip this step. Refer to Package Contents / Breakdown of Parts, to determine if you have broken cable safety devices.

Locate the left hand broken cable safety device. Reference step Bottom Corner Brackets to secure the counterbalance cable to the broken cable safety device. Next, align the broken cable safety device horizontally with the bottom edge of the bottom section and also align the broken cable safety device vertically with the left bottom edge of the bottom section. Attach the broken cable safety device to the bottom section with (5) 1/4" - 20 x 7/8" self drilling screws, as shown. Next, thread the counterbalance lift cable through the arm of the broken cable safety device. Repeat the same process for the right hand side.

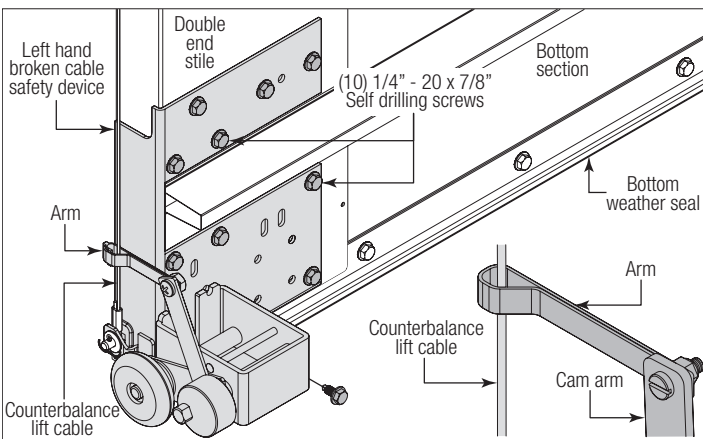
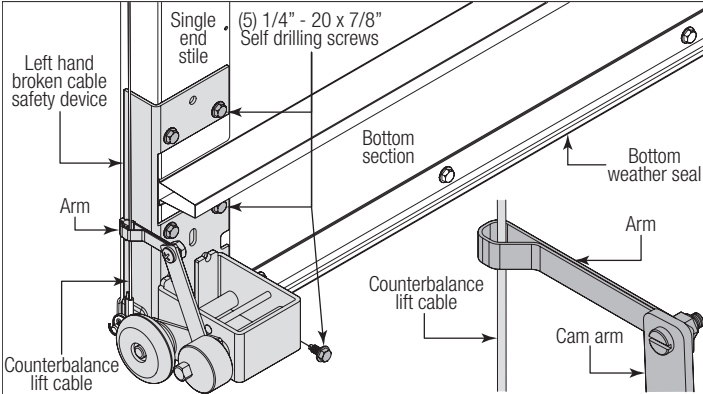

7 Attaching Hinges

NOTE: Refer to door section identification, located in the pre-installation section of this manual to determine what size sections you need to use as your lock (second) section, intermediate (third) section, intermediate (fourth) section, intermediate (fifth) section, intermediate (sixth) section, intermediate (seventh) section, intermediate (eighth) section, intermediate (ninth) section and top section. Measure your sections to make sure they are the correct height as indicated on the chart.

NOTE: The graduated hinges can be identified by the number stamped onto their lower hinge leaf.

The graduated end hinge sequence is dependent on your door model, track size (2" or 3") or

if you have GX4000. Refer to Graduated End Hinge Schedules below.

Graduated End Hinge Schedule			
Section Type	Graduated End Hinge Number		
	2" Track	3" Track or TS125 With 2" Track (< = 9 Sections High)	3" Track (> 9 Sections High)
Intermediate IX	N/A	N/A	#9
Intermediate VIII	N/A	N/A	#9
Intermediate VII	N/A	N/A	#8
Intermediate VI	N/A	N/A	#8
Intermediate V	#7	#10	#7
Intermediate IV	#6	#9	#7
Intermediate III	#5	#8	#6
Intermediate II	#4	#7	#6
Intermediate I	#3	#5	#4
Lock	#2	#4	#3
Bottom	#1	#3	#3

Graduated End Hinge Schedule For Thermospan® 150 with GX4000 Bottom Section			
Section Type	Graduated End Hinge Number		
	2" Track	3" Track (< = 8 Sections High)	3" Track (> 8 Sections High)
Intermediate IX	N/A	N/A	#9
Intermediate VIII	N/A	N/A	#9
Intermediate VII	N/A	N/A	#8
Intermediate VI	N/A	N/A	#8
Intermediate V	#8	#10	#7
Intermediate IV	#7	#9	#7
Intermediate III	#6	#8	#6
Intermediate II	#5	#7	#6
Intermediate I	#4	#6	#5
Lock	#3	#5	#5
Bottom	#1	#3	#3

Graduated End Hinge Schedule For Thermospan® 150 with GX4000 Bottom and Lock Sections			
Section Type	Graduated End Hinge Number		
	2" Track	3" Track (< = 8 Sections High)	3" Track (> 8 Sections High)
Intermediate IX	N/A	N/A	#9
Intermediate VIII	N/A	N/A	#9
Intermediate VII	N/A	N/A	#8
Intermediate VI	N/A	N/A	#8
Intermediate V	#8	#10	#7
Intermediate IV	#7	#9	#7
Intermediate III	#6	#8	#6
Intermediate II	#5	#7	#6
Intermediate I	#4	#5	#4
Lock	#2	#4	#3
Bottom	#1	#3	#3

Graduated End Hinge Schedule For Thermospan® 150 with GX4000 Bottom, Lock and Intermediate I Sections			
Section Type	Graduated End Hinge Number		
	2" Track	3" Track (< = 8 Sections High)	3" Track (> 8 Sections High)
Intermediate IX	N/A	N/A	#9
Intermediate VIII	N/A	N/A	#9
Intermediate VII	N/A	N/A	#8
Intermediate VI	N/A	N/A	#8

Graduated End Hinge Schedule For Themospan® 150 with GX4000 Bottom, Lock and Intermediate I Sections

Section Type	Graduated End Hinge Number		
	2" Track	3" Track (<= 8 Sections High)	3" Track (> 8 Sections High)
Intermediate V	#8	#10	#7
Intermediate IV	#7	#9	#7
Intermediate III	#6	#8	#6
Intermediate II	#5	#7	#6
Intermediate I	#3	#5	#4
Lock	#2	#4	#3
Bottom	#1	#3	#3

Locate the bottom section and the appropriate graduated end hinges for the end stiles. Starting on the left hand side of the bottom section, align the lower hinge leaf of the graduated end hinge over the two punch marks, located at the top of the end stile. Fasten each graduated end hinge to the section using the appropriate 1/4" - 20 self drilling screws using one of the following scenarios listed below:

For door model Themospan® 125 and door width less than or equal to 18'4" uses 1/4" - 20 x 11/16" self drilling screws.

For door models Themospan® 150, 200 or 200-20 and door width less than or equal to 18'2" uses 1/4" - 20 x 11/16" self drilling screws.

For all Themospan® door models and door width greater than 18'2" uses 1/4" - 20 x 7/8" self drilling screws.

Repeat the same process for the right hand side.

TO INSTALL CENTER HINGES ON SECTIONS WITH NO FINS: Place the lower hinge leaf of the center hinge over the dimples, located at the top of the section. Attach lower hinge leaves to the section using the appropriate 1/4" - 20 self drilling screws using one of the following scenarios listed below:

For door model Themospan® 125 and door width less than or equal to 18'4" uses 1/4" - 20 x 11/16" self drilling screws.

For door models Themospan® 150, 200 or 200-20 and door width less than or equal to 18'2" uses 1/4" - 20 x 11/16" self drilling screws.

For all Themospan® door models and door width greater than 18'2" uses 1/4" - 20 x 7/8" self drilling screws.

Repeat the same process for other center hinge(s).

TO INSTALL HALF CENTER HINGES ON SECTIONS WITH FINS "ALUMINUM SASH SECTION": Position the half center hinge on top of the fin and in front of the center stile. Align the bottom (2) holes in the half center hinge over the (2) pre-punch holes in the fin. Secure the half center hinge to the fin using (2) 1/4" - 20 x 9/16" track bolts and (2) 1/4" - 20 flange hex nuts, as shown. Repeat the same process for the other half center hinges.

NOTE: Depending on the width of your door, you may have only one center hinge (dimples) marking.

IMPORTANT: ONCE THE 1/4" - 20 SELF DRILLING SCREWS ARE SNUG AGAINST THE LOWER HINGE LEAFS, TIGHTEN AN ADDITIONAL 1/4 TO 1/2 TURN TO RECEIVE MAXIMUM DESIGN HOLDING POWER.

IMPORTANT: PUSH & HOLD THE HINGE LEAF AND OR STRUT SECURELY AGAINST THE SECTION WHILE SECURING WITH THE 1/4" - 20 SELF DRILLING SCREWS. THERE SHOULD BE NO GAP BETWEEN THE HINGE LEAF AND THE SECTION.

Repeat graduated end hinge / center hinge / half center hinge attachment using the appropriate graduated end hinges for all remaining sections, except for the top section.

IMPORTANT: WHEN PLACING TRACK ROLLERS INTO THE #2 GRADUATED END HINGES AND HIGHER, THE TRACK ROLLER GOES INTO HINGE TUBE FURTHEST AWAY FROM SECTION.

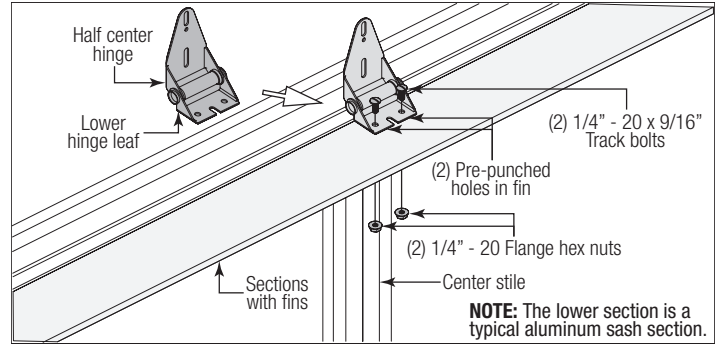
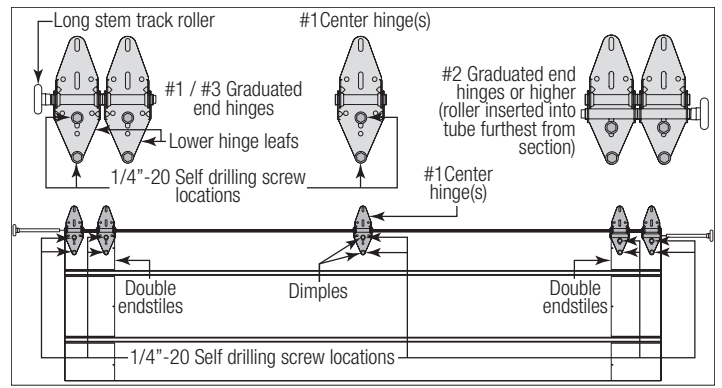
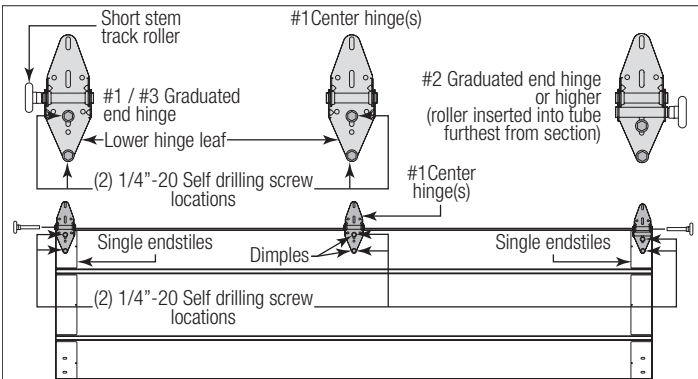

8 Attaching Struts

NOTE: Refer to door section identification, located in the pre-installation section of this manual to determine what size sections you need to use as your bottom (first), lock (second) section, intermediate (third) section, intermediate (fourth) section, intermediate (fifth) section, intermediate (sixth) section, intermediate (seventh) section and top section. Measure your sections to make sure they are the correct height as indicated on the chart.

NOTE: Depending on your door model and door width, one or more sections may require a strut.

IMPORTANT: WHEN REFERRING TO THE STRUTTING SCHEDULES BELOW TO DETERMINE HOW MANY STRUTS OR TRUSSES YOUR DOOR NEEDS AND ON WHAT SECTIONS THEY ARE NEEDED TO BE INSTALLED.

NOTE: Sections not noted in the strutting schedule, do not require a strut.

NOTE: Refer to the strutting schedules below to determine the placement of struts and or trusses for your door. Be sure to use the proper schedules for the type of door model and the quantity of sections your door came with.

All Section Heights Strutting Schedule For Themospan® Models 125, 200, 200-20		
Section Type	Top Or Bottom Rib Of Section	Placement
Top	Top Rib	X
	Bottom Rib	-
Intermediate VIII	Top Rib	X
	Bottom Rib	-
Intermediate VII	Top Rib	X
	Bottom Rib	-
Intermediate VI	Top Rib	X
	Bottom Rib	-
Intermediate V	Top Rib	X
	Bottom Rib	-
Intermediate IV	Top Rib	X
	Bottom Rib	-
Intermediate III	Top Rib	X
	Bottom Rib	-
Intermediate II	Top Rib	X
	Bottom Rib	-
Intermediate I	Top Rib	X
	Bottom Rib	-

All Section Heights Strutting Schedule For Themospan® Models 125, 200, 200-20		
Section Type	Top Or Bottom Rib Of Section	Placement
Lock	Top Rib	X
	Bottom Rib	-
Bottom	Top Rib	X
	Bottom Rib	-

Even Sections Heights Strutting Schedule For Themospan® Model 150			
Number Of Sections High	Section Type	Top Or Bottom Rib Of Section	Placement
10	Top	Top Rib	X
		Bottom Rib	-
9	Intermediate VII	Top Rib	X
		Bottom Rib	X
8	Intermediate VI	Top Rib	X
		Bottom Rib	-
7	Intermediate V	Top Rib	X
		Bottom Rib	X
6	Intermediate IV	Top Rib	X
		Bottom Rib	-
5	Intermediate III	Top Rib	X
		Bottom Rib	X
4	Intermediate II	Top Rib	X
		Bottom Rib	-
3	Intermediate I	Top Rib	X
		Bottom Rib	X
2	Lock	Top Rib	X
		Bottom Rib	-
1	Bottom	Top Rib	X
		Bottom Rib	X

Odd Sections Heights Strutting Schedule For Themospan® Model 150			
Number Of Sections High	Section Type	Top Or Bottom Rib Of Section	Placement
11	Top	Top Rib	X
		Bottom Rib	X
10	Intermediate VIII	Top Rib	X
		Bottom Rib	-
9	Intermediate VII	Top Rib	X
		Bottom Rib	X
8	Intermediate VI	Top Rib	X
		Bottom Rib	-
7	Intermediate V	Top Rib	X
		Bottom Rib	X
6	Intermediate IV	Top Rib	X
		Bottom Rib	-
5	Intermediate III	Top Rib	X
		Bottom Rib	X
4	Intermediate II	Top Rib	X
		Bottom Rib	-
3	Intermediate I	Top Rib	X
		Bottom Rib	X
2	Lock	Top Rib	X
		Bottom Rib	-
1	Bottom	Top Rib	X
		Bottom Rib	X

Using sawhorses, lay the appropriate section on a flat smooth surface. Place the strut (U-shaped) / truss (U-shaped) over the appropriate rib of the door section. Center the strut (U-shaped) / truss (U-shaped) from side to side on the section. Fasten each end of the strut (U-shaped) / truss (U-shaped) to the end cap with (2) 1/4" - 20 x 7/8" self drilling screws. Push strut (U-shaped) / truss (U-shaped) tight against section and pre-drill 9/32" holes every 30" through the strut (U-shaped) / truss (U-shaped) and rib. Fasten the strut (U-shaped) / truss (U-shaped) to the rib of the section using (1) 1/4" - 20 x 1-1/4" hex head bolt and (1) 1/4" - 20 flange hex nut at each pre-drilled hole.

Repeat the same process for all remaining sections.

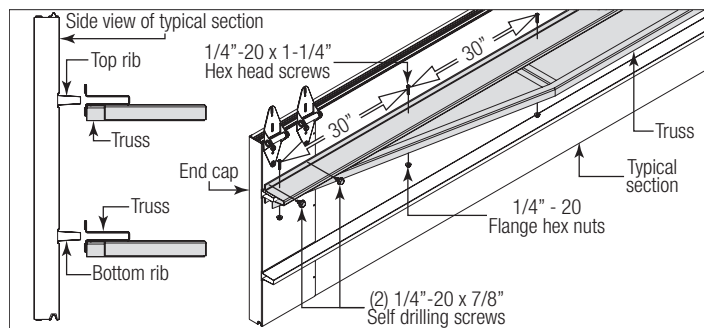
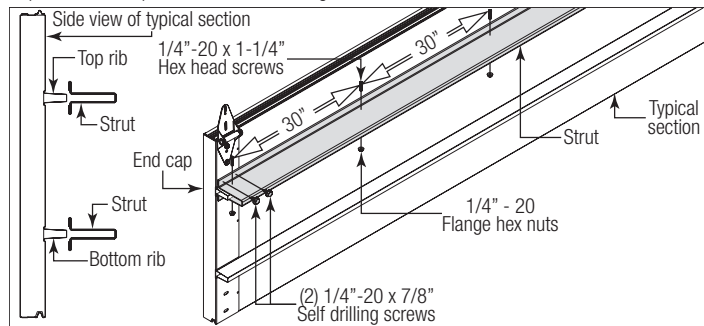

NOTE: For door model Themospan® 150 and door width from 16'3" to 18'2" with intermediate aluminum full view sections, don't install strut.

Place the strut on the intermediate section up against the bottom of the hinges. Center the strut side to side on the section surface, as shown. Secure the strut to the section using (2) 1/4" - 20 x 7/8" self drilling screws at each end locations and (2) 1/4" - 20 x 7/8" self drilling screws at each center stile location(s).

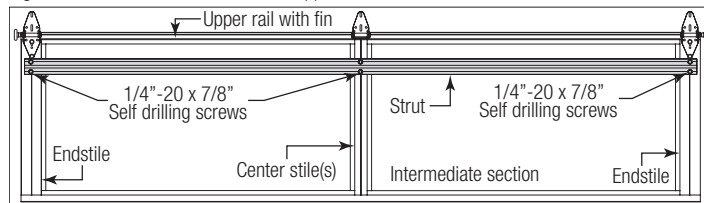

9 Attaching Top Fixtures

NOTE: Depending on your door, you may have Top Fixture Bases and Top Fixture Slides or you may have Top Fixture Assemblies. Refer to Illustrations / Package Contents or Breakdown of Parts, to determine which Top Fixtures you have.

NOTE: If your door came with two top fixtures, then one top fixture and a short stem track roller are required for each side.

NOTE: If your door came with four top fixtures, then two top fixtures and a long stem track roller are required for each side.

IF YOU HAVE TOP FIXTURE ASSEMBLIES: Starting on the left hand side of the top section, place the top of the top fixture base flush with the top edge of section. Fasten to section using the appropriate 1/4" - 20 self drilling screws using one of the following scenarios listed below:

For door model Themospan® 125 and door width less than or equal to 18'4" uses 1/4" - 20 x 11/16" self drilling screws.

For door models Themospan® 150, 200 or 200-20 and door width less than or equal to 18'2" uses 1/4" - 20 x 11/16" self drilling screws.

For all Themospan® door models and door width greater than 18'2" uses 1/4" - 20 x 7/8" self drilling screws.

Insert the appropriate short / long stem track roller into each top fixture slide(s). Repeat the same process for other top fixture assembly(s).

NOTE: If needed, ensure the top fixture slides are able to slide back and forth along the top fixture base. If needed, loosen the 5/16" - 18 hex nut.

The top fixture assembly will be tightened and adjusted later, in step, Adjusting Top Fixtures.

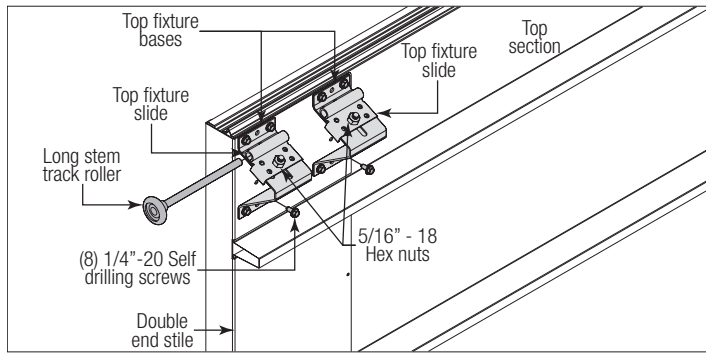
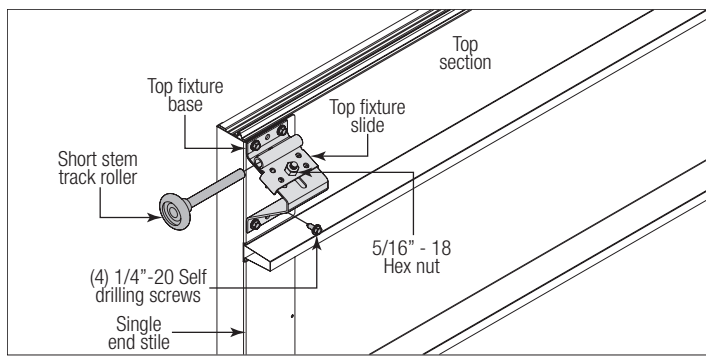

IF YOU HAVE TOP FIXTURE BASES AND TOP FIXTURE SLIDES: Loosely secure the top fixture slide and the "L" reinforcement bracket (if applicable) to the top fixture base using (1) 5/16" - 18 x 3/4" carriage bolt and (1) 5/16" - 18 hex nut, as shown. Repeat for other top fixtures.

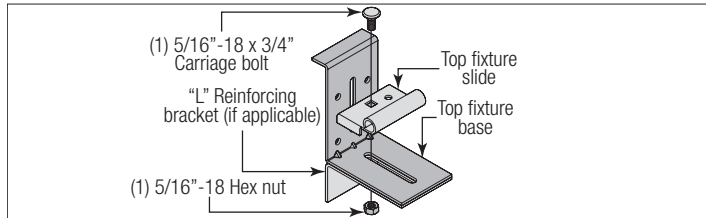

Starting on the left hand side of the top section, align the lip of the top fixture base on top of the corner of the top section and even with the edge of the section. Fasten to section using the appropriate 1/4" - 20 self drilling screws using one of the following scenarios listed below:

For door model Themospan® 125 and door width less than or equal to 18'4" uses 1/4" - 20 x 11/16" self drilling screws.

For door models Themospan® 150, 200 or 200-20 and door width less than or equal to 18'2" uses 1/4" - 20 x 11/16" self drilling screws.

For all Themospan® door models and door width greater than 18'2" uses 1/4" - 20 x 7/8" self drilling screws.

Fasten the "L" reinforcement bracket (if applicable) to the section using (1) 1/4" - 20 x 11/16" self drilling screw. Repeat the same process for other top fixture assembly(s). Insert the appropriate short / long stem track roller into each top fixture slide(s).

NOTE: If needed, ensure the top fixture slides are able to slide back and forth along the top fixture base. If needed, loosen the 5/16" - 18 hex nut.

The top fixture assembly will be tightened and adjusted later, in step, Adjusting Top Fixtures.

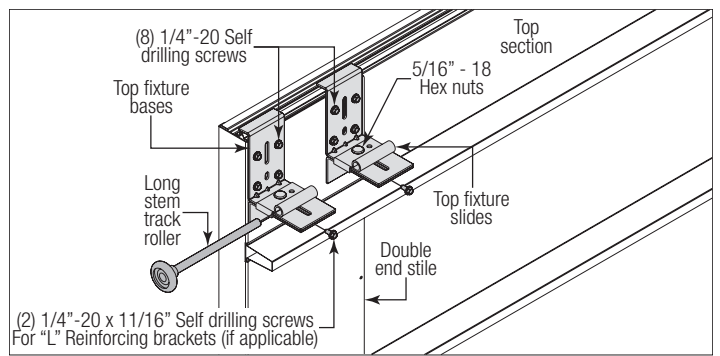
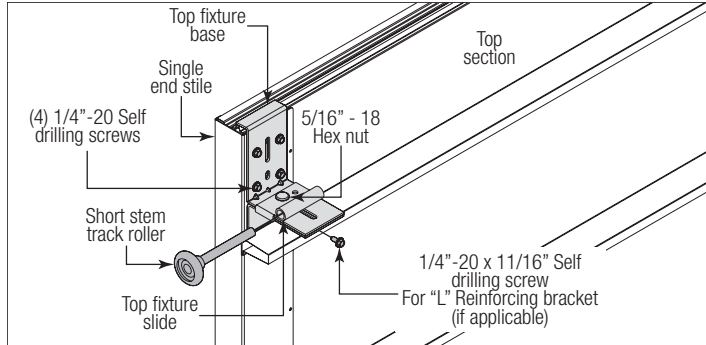

10 Attaching Top Head Seal

NOTE: If you don't have a top head seal, then skip this step. Refer to Package Contents / Breakdown of Parts, to determine if you have a top head seal.

NOTE: Refer to door section identification, located in the pre-installation section of this manual. Refer to Package Contents / Breakdown of Parts, to determine your top section.

Using sawhorses, lay the top section on a flat smooth surface. Position the top head seal on the top section, making sure the straight portion of the head seal is facing the outside of the section and is pointing upward, as shown.

NOTE: Since the top head seal will tend to want to slip off the tongue of the top section prior to securing, it is advisable to have someone hold the top section and another person holding the top head seal in position, while securing it to the top section.

While holding the top head seal in position, use the #6 - 20 x 1/2" screws to secure the head seal to the tongue of the top section, as shown. Screws should be installed at each end and at 18" intervals.

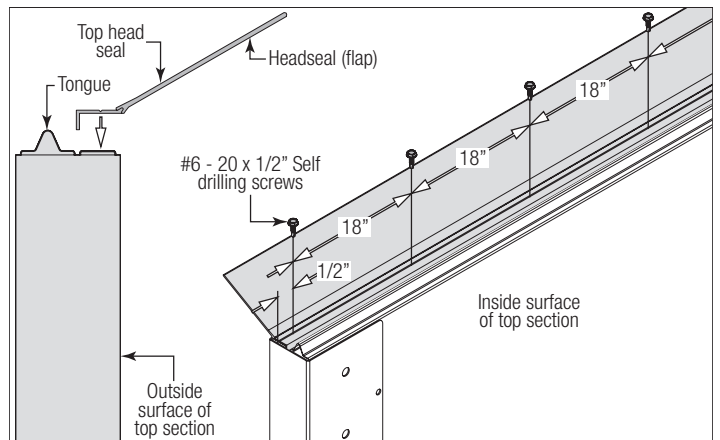
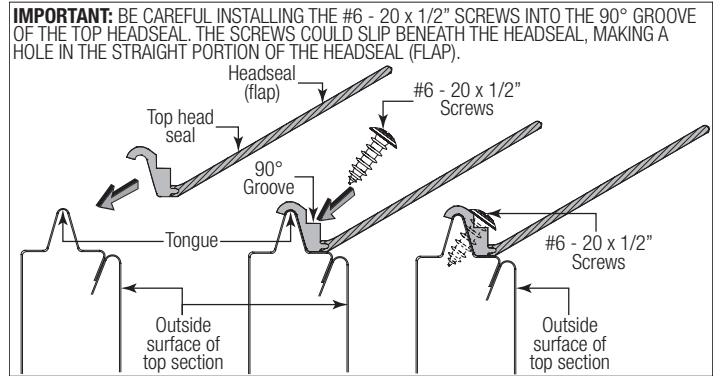

11 Positioning Bottom Section

Center the bottom section in the door opening. Level the section using wooden shims (if necessary) under the bottom section. When the bottom section is leveled, temporarily hold it in place by driving a nail into the jamb and bending it over the edge of the bottom section on both sides.

NOTE: For wider size doors, more than two wooden shims (shown in illustration) might be needed to level the bottom section.

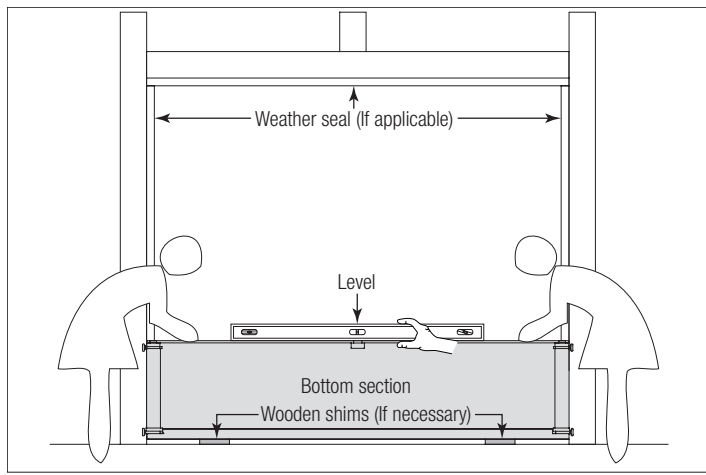

12

Attaching Wall Angle Seals

NOTE: If you don't have wall angle seals, then skip this step. Refer to Package Contents and/or illustrations below, to determine which wall angle seals you have received.

Starting with the left hand wall angle, align the profile of the wall angle seal with the inside edge of wall angle. Next, slide wall angle seal over the inside edge of wall angle until seal is flush up against the edge of wall angle, as shown. Repeat the same process for the right hand side wall angle.

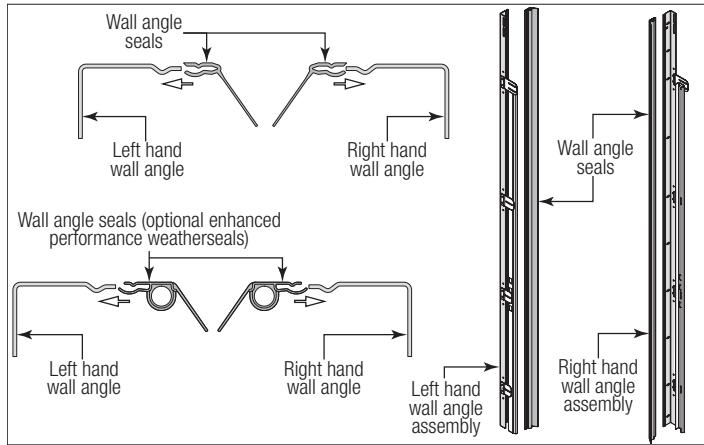

13

Attaching Vertical Tracks To Jamb

NOTE: Depending on your door, you may have Fully Adjustable Flag Angles, Riveted Vertical Track Assemblies or you may have Angle Mount Vertical Track Assemblies. Refer to Package Contents / Breakdown of Parts, to determine which Flag Angles / Vertical Track Assemblies you have.

IMPORTANT: IF YOUR DOOR IS TO BE INSTALLED PRIOR TO A FINISHING CONSTRUCTION OF THE BUILDING'S FLOOR, THE VERTICAL TRACKS AND THE DOOR BOTTOM SECTION ASSEMBLY SHOULD BE INSTALLED SUCH THAT WHEN THE FLOOR IS CONSTRUCTED, NO DOOR OR TRACK PARTS ARE TRAPPED IN THE FLOOR CONSTRUCTION.

IMPORTANT: THE TOPS OF THE VERTICAL TRACKS MUST BE LEVEL FROM SIDE TO SIDE. IF THE BOTTOM SECTION WAS SHIMMED TO LEVEL IT, THE VERTICAL TRACK ON THE SHIMMED SIDE MUST BE RAISED THE HEIGHT OF THE SHIM.

NOTE: Make sure the counterbalance lift cable is located between the track rollers and the door jamb.

Starting on the left hand side of the bottom section, remove the nail. Position the left hand vertical track assembly over the track rollers of the bottom section and install, as shown. Drill 3/16" pilot holes into the door jamb for the lag screws.

LOOSELY FASTEN WALL ANGLES TO ONE OF THE FOLLOWING SCENARIOS LISTED BELOW:

Wood jombs, using 5/16" x 1-5/8" lag screws. Drill 3/16" pilot holes into the wood jamb for the lag screws.

Steel jombs, using 5/16" x 1" self drilling screws.

Pre-cast concrete, using 3/8" x 3" sleeve anchor (not supplied).

NOTE: Products being installed to pre-cast or block must use a 3/8" x 3" sleeve anchor to attach the wall angle to the building, as shown. Use the slots in the wall angle as a drill template and drill a 3/8" hole (3-1/2" deep) and secure to anchor.

WARNING

DO NOT USE SLEEVE ANCHORS ON HOLLOW BLOCK.

FOR 2" TRACK: Tighten fasteners, securing the bottom jamb bracket in the vertical track assemblies / bottom slot in the wall angle to jamb, maintain 3/8" to 5/8" spacing, between the bottom section and vertical track.

FOR 3" TRACK: Tighten fasteners, securing the bottom jamb bracket in the vertical track assemblies / bottom slot in the wall angle to jamb, maintain 1/2" to 3/4" spacing, between the bottom section and vertical track.

Allow proper clearance as shown and use the values as illustrated in the Side Room Requirements (Minimum Distance Required), located in the pre-installation section of this manual.

Hang counterbalance lift cable over flag angle / angle mount. Repeat same process for other side.

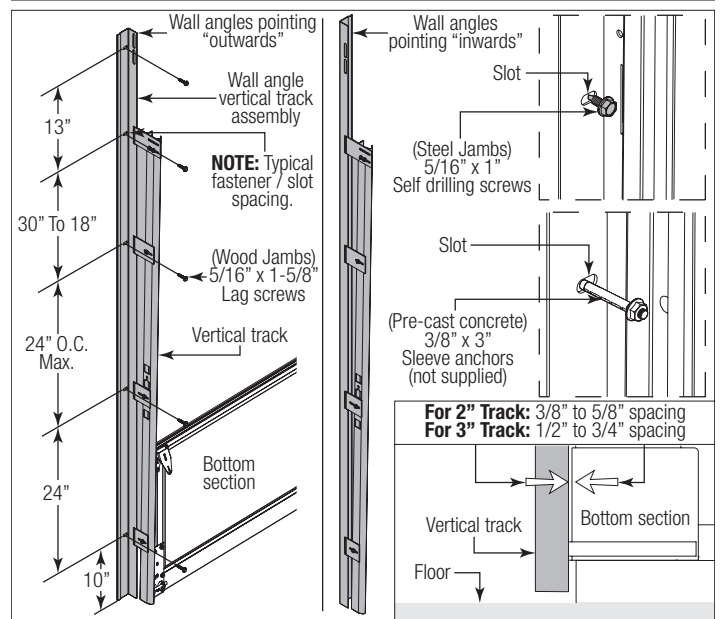
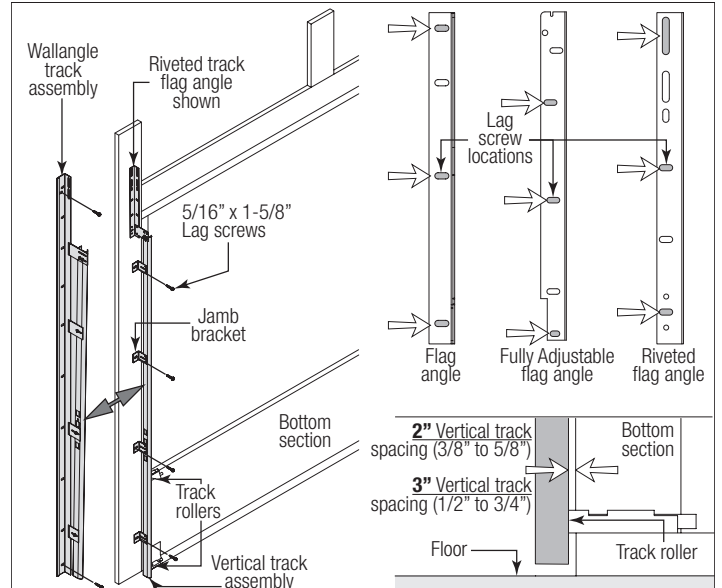

14

Stacking Sections

NOTE: Refer to door section identification, located in the pre-installation section of this manual.

NOTE: The sections can be identified by the installed graduated end hinges. The smallest graduated end hinge on section should be stacked on top of the bottom section, with each end hinge increasing as the sections are stacked, see Breakdown of Parts.

NOTE: Make sure graduated end and center hinges are flipped down, when stacking another section on top.

With assistance, lift second (Lock) section and guide the track rollers into the vertical tracks. Lower section until it is seated against bottom section. Flip hinges up. Fasten center hinge(s)

first; then graduated end hinges last using the appropriate 1/4" - 20 self drilling screws using one of the following scenarios listed below:

For door model Themospan® 125 and door width less than or equal to 18'4" uses 1/4" - 20 x 11/16" self drilling screws.

For door models Themospan® 150, 200 or 200-20 and door width less than or equal to 18'2" uses 1/4" - 20 x 11/16" self drilling screws.

For all Themospan® door models and door width greater than 18'2" uses 1/4" - 20 x 7/8" self drilling screws.

Repeat same process for other sections, except top section.

IMPORTANT: PUSH & HOLD THE UPPER HINGE LEAFS SECURELY AGAINST THE SECTIONS WHILE SECURING WITH 1/4" - 20 SELF-DRILLING SCREWS. THERE SHOULD BE NO GAP BETWEEN THE HINGE LEAFS AND THE SECTIONS.

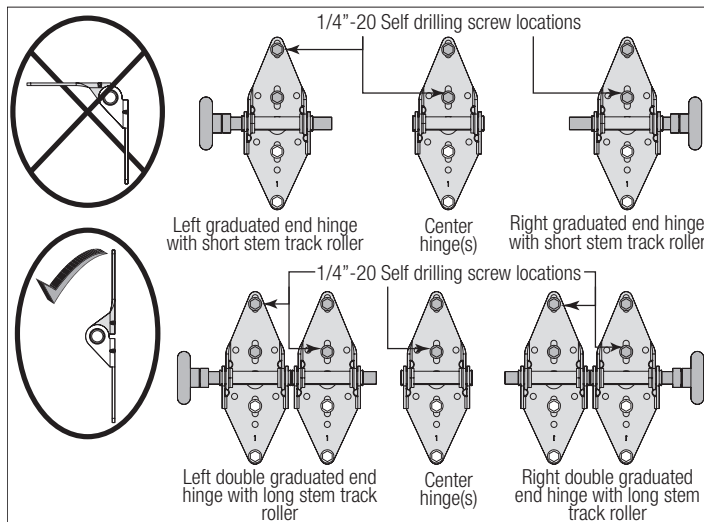
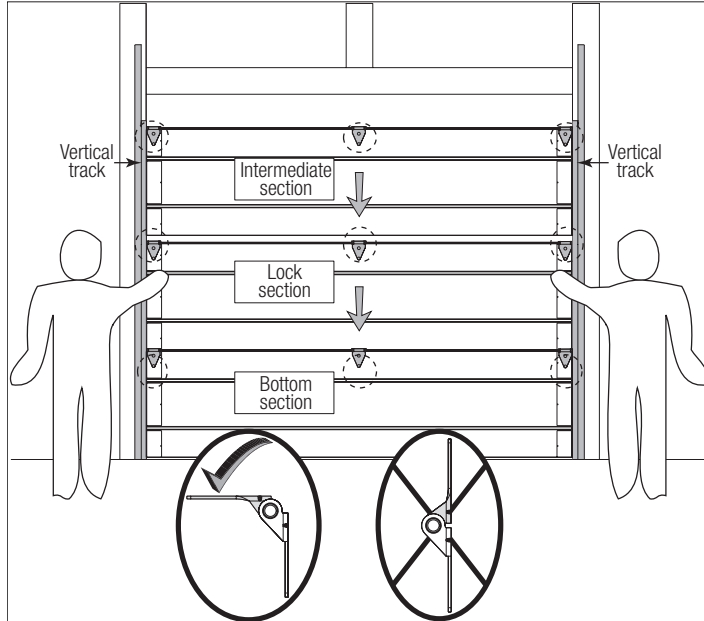

15

Stacking Top Section

Place the top section in the opening. Install a nail to prevent the top section from falling backwards. Now, flip up the hinge leaves, hold tight against section, and fasten center hinges first and end hinges last (refer to step, Stacking Sections). Vertical track alignment is critical.

POSITION FLAG ANGLE OR ANGLE MOUNT FROM THE EDGE OF THE DOOR:

FOR 2" TRACK APPLICATIONS: 1-11/16" (43 mm) to 1-3/4" (44 mm) for smooth, safe door operation.

FOR 3" TRACK APPLICATIONS: 2-3/16" (56 mm) to 2-1/4" (57 mm) for smooth, safe door operation

Tighten the bottom lag screw. Flag angles / Angle mount must be parallel to the door sections. Repeat for other side.

FOR 2" TRACK APPLICATIONS: Door width plus 3-3/8" (86mm) to 3-1/2" (89 mm) for smooth, safe door operation.

FOR 3" TRACK APPLICATIONS: Door width plus 4-7/8" (124mm) to 5" (127 mm) for

smooth, safe door operation.

Complete the vertical track installation by securing the fasteners to the jamb. Push the vertical track against the track rollers so that the track rollers are touching the deepest part of the curved side of the track; tighten all the track bolts and nuts. Repeat for other side.

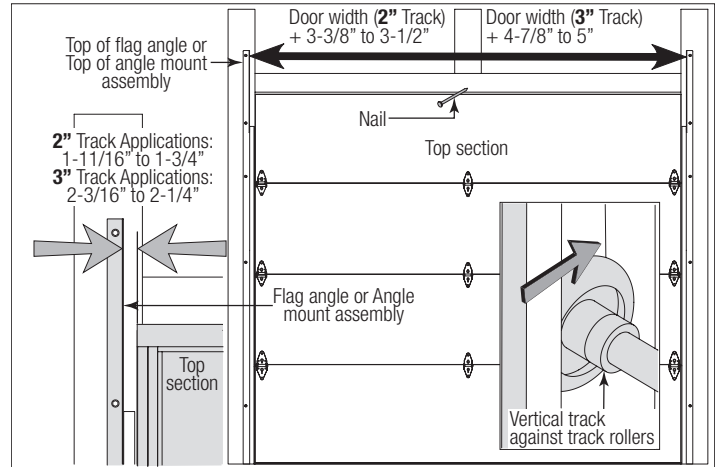

16

Attaching Drawbar Operator Bracket

NOTE: If you don't have a drawbar operator bracket, then skip this step. Refer to Illustrations shown below, Package Contents or Breakdown of Parts, to determine which drawbar operator bracket you have.

NOTE: If you're installing a drawbar operator, the drawbar operator bracket must be mounted and secured prior to installing top section.

IMPORTANT: WHEN CONNECTING A TROLLEY TYPE GARAGE DOOR OPENER TO THIS DOOR, A WAYNE DALTON OPERATOR / TROLLEY BRACKET MUST BE SECURELY ATTACHED TO THE TOP SECTION OF THE DOOR IF ONE HAS BEEN PROVIDED, ALONG WITH ANY STRUTS PROVIDED WITH THE DOOR (IF A WAYNE DALTON OPERATOR / TROLLEY BRACKET WAS NOT PROVIDED WITH YOUR DOOR, THAN USE THE ONE PROVIDED BY YOUR OPERATOR MANUFACTURER). THE INSTALLATION OF THE OPERATOR MUST BE ACCORDING TO MANUFACTURER'S INSTRUCTIONS AND FORCE SETTINGS MUST BE ADJUSTED PROPERLY.

NOTE: For retro fit applications, the drawbar operator bracket must be aligned with an existing operator.

DRAWBAR OPERATOR BRACKET: Locate the center of the top section and seat the drawbar operator bracket on the top rib of the top section. For retro fit applications, the drawbar operator bracket must be aligned with an existing drawbar operator. Using the drawbar operator bracket as a template, mark and pre-drill, 9/32" holes into the top rib of the top section. Secure the drawbar operator bracket to the top rib of the top section using (2) 1/4" - 20 x 1-1/2" hex head bolts and (2) 1/4" - 20 hex nuts, as shown.

For doors less than 16'3" wide and not exceeding 160 sq. ft.

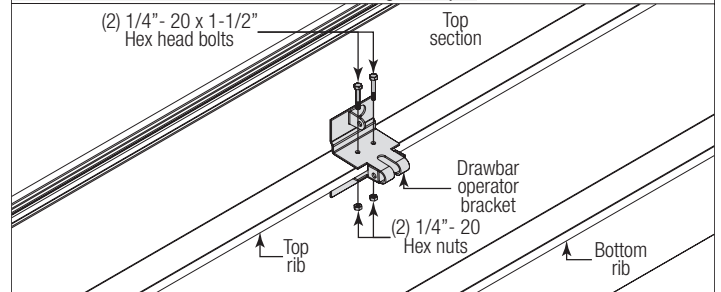

For doors over 16'2" wide through 20'2" and not exceeding 240 sq. ft., two drawbar operator brackets requires to be attached together with perforated angles.

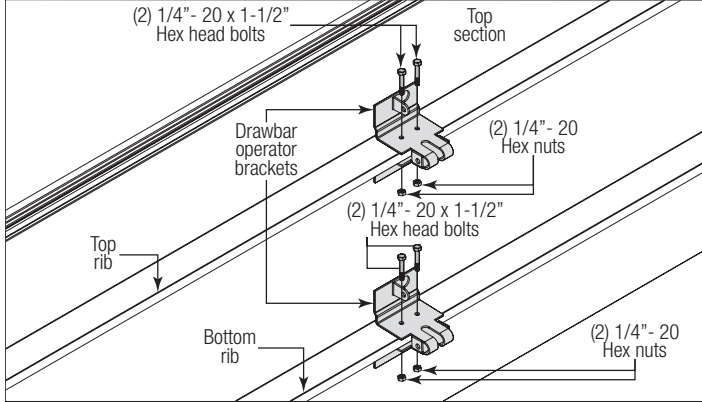

DRAWBAR OPERATOR BRACKET (RECTANGULAR): Locate the center of the top section and position the drawbar operator bracket in between the top and bottom ribs of the top section. Using the drawbar operator bracket as a template, mark and pre-drill, 9/32" holes into the top and bottom ribs of the top section. Secure the drawbar operator bracket to the ribs of the top section using (2) 1/4" - 20 x 1-1/2" hex head bolts and (2) 1/4" - 20 hex nuts, as shown.

NOTE: Space operator brackets such that the section width is divided into three approximately equal segments. This spacing may be adjusted as needed to avoid interference between the trolley rails and the springs.

Doors over 25'2" wide and any door height, requires two 38" drawbar operator brackets.

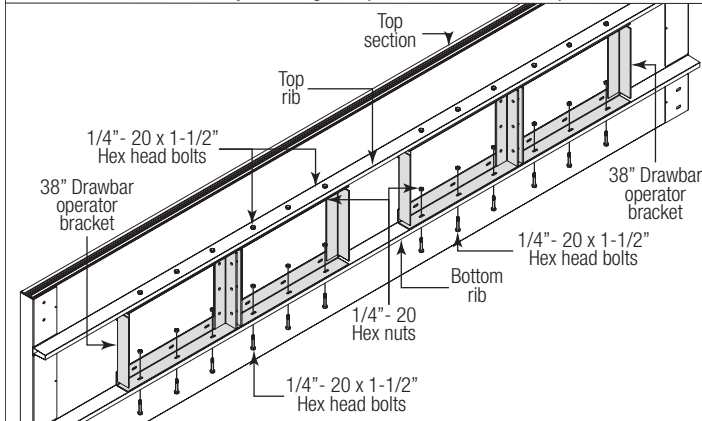

Doors over 20'2" through 25'2" wide and not exceeding 400 sq. ft., requires one 38" drawbar operator bracket.

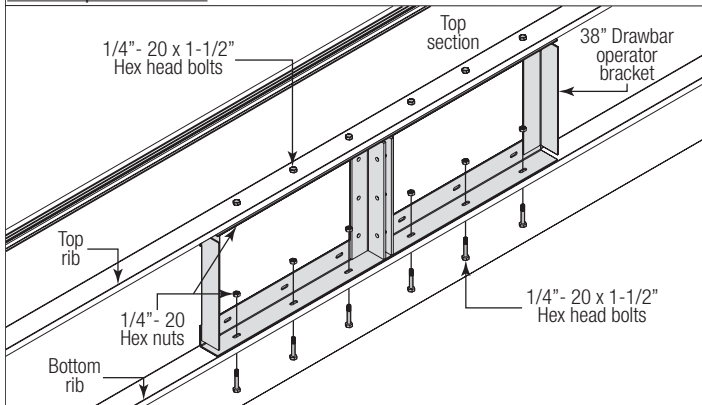

Attaching Horizontal Tracks

17

NOTE: Depending on your door, you may have Fully Adjustable Flag Angles, Riveted Vertical Track Assemblies or you may have Angle Mount Vertical Track Assemblies. Refer to Package Contents / Breakdown of Parts, to determine which Flag Angles / Vertical Track Assemblies you have.

WARNING

DO NOT RAISE DOOR UNTIL HORIZONTAL TRACKS ARE SECURED AT REAR, AS OUTLINED IN STEP, REAR BACK HANGS, OR DOOR COULD FALL FROM OVERHEAD POSITION CAUSING SEVERE OR FATAL INJURY.

IMPORTANT: PRIOR TO INSTALLING THE HORIZONTAL TRACKS, USE CABLES OR CHAINS TO TEMPORARILY SUSPEND THE REAR PORTION OF HORIZONTAL TRACKS.

WARNING

DO NOT USE ROPES, SINCE EDGES OF HORIZONTAL TRACKS AND ANGLES ARE VERY SHARP.

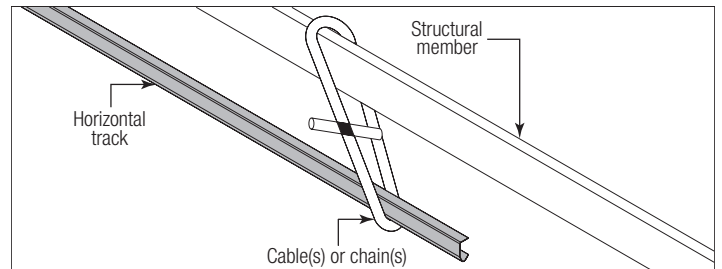

IF YOU HAVE FLAG ANGLES: To install horizontal track, place the curved end over the top track roller of the top section. Align the bottom of the horizontal track with the top of the vertical track. Tighten the horizontal track to the flag angle with (2) 1/4" - 20 x 9/16" track bolts and (2) 1/4" - 20 flange hex nuts.

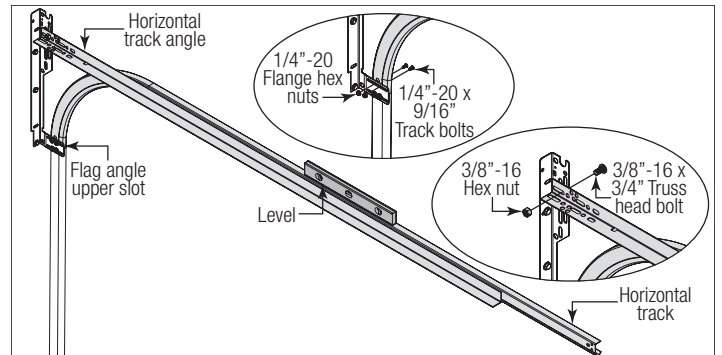

IF YOU HAVE ANGLE MOUNT: To install horizontal track, place the curved end over the top track roller of the top section. Align the bottom of the horizontal track with the top of the vertical track. Tighten the horizontal track to the angle mount with (2) 1/4" - 20 x 9/16" track bolts and (2) 1/4" - 20 flange hex nuts.

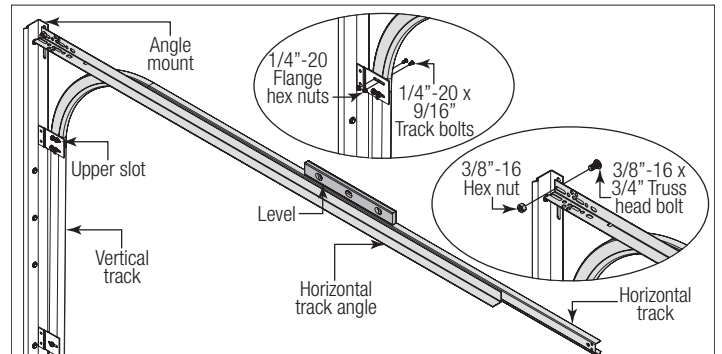

Next level the horizontal track assembly and bolt the horizontal track angle to the first encountered slot in the flag angle / angle mount using (1) 3/8" - 16 x 3/4" truss head bolt and (1) 3/8" - 16 hex nut. Repeat for other side. Remove nail that was temporarily holding the top section in position.

IMPORTANT: FAILURE TO REMOVE NAIL BEFORE ATTEMPTING TO RAISE DOOR COULD CAUSE PERMANENT DAMAGE TO TOP SECTION.

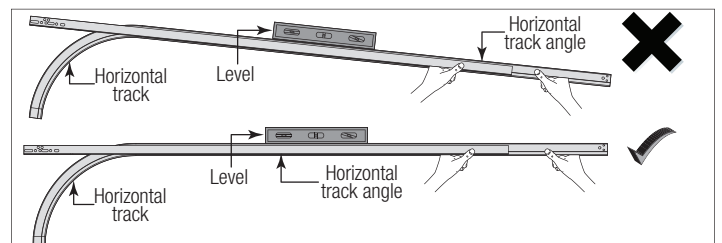

18

Adjusting Top Fixtures

Tools Required: 9/16" Wrench, 1/2" Wrench, Step ladder, Safety glasses, Leather gloves

NOTE: Depending on your door, you may have Top Fixture Bases and Top Fixture Slides or you may have Top Fixture Assemblies. Refer to Illustrations / Package Contents / Parts Breakdown, to determine which Top Fixtures you have.

IF YOU HAVE TOP FIXTURE ASSEMBLIES: With horizontal tracks installed, you can now adjust the top fixtures. Vertically align the top section of the door with the lower sections. Once aligned, position the top fixture slide(s), out against the horizontal track. Maintaining the slide(s) position, tighten the 1/4" - 20 flange hex nut(s) to secure the top fixture slide(s) to the top fixture base(s). Repeat for other side. Secure each of the top fixture slide further using (1) 1/4" - 20 x 9/16" track bolt and (1) 1/4" - 20 flange hex nut through any two aligning holes in the top fixture slide and top fixture base, as shown.

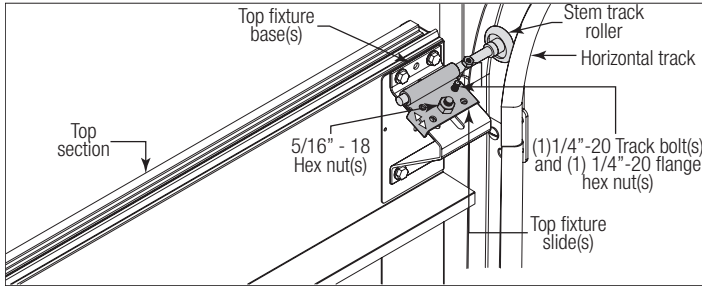

IF YOU HAVE TOP FIXTURE BASES AND TOP FIXTURE SLIDES: With horizontal tracks installed, you can now adjust the top fixtures. Vertically align the top section of the door with the lower sections. Once aligned, position the top fixture slide, out against the horizontal track. Maintaining the slide(s) position, tighten the (1) 5/16" - 18 hex nut(s) to secure the top fixture slide(s) to the top fixture base(s). Repeat for other side.

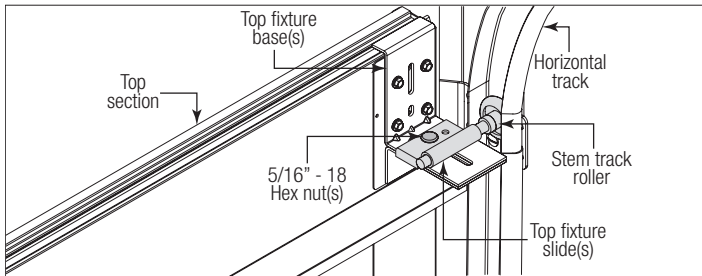

COUNTERBALANCE INSTALLATION INSTRUCTIONS

19

Attaching End Bearing Brackets

IMPORTANT: RIGHT AND LEFT HAND IS ALWAYS DETERMINED FROM INSIDE THE BUILDING LOOKING OUT.

WARNING

INSTALL END BEARING BRACKETS TO SOLID STRUCTURAL MEMBERS ONLY. DO NOT INSTALL OVER DRY WALL OR PANELING. FAILURE TO INSTALL END BEARING BRACKETS TO SOLID STRUCTURAL MEMBERS CAN CAUSE SEVERE OR FATAL INJURY.

WARNING

FAILURE TO USE PROPER NUMBER OF FASTENERS CAN RESULT IN SUDDEN SPRING TENSION RELEASE, CAUSING SEVERE OR FATAL INJURY.

NOTE: Spring pads must be securely anchored before proceeding, as shown. The pads must be flush with the jambs.

IMPORTANT: RIGHT AND LEFT HAND IS ALWAYS DETERMINED FROM INSIDE THE BUILDING LOOKING OUT.

NOTE: End bearing brackets are right hand and left hand.

Attach the left hand end bearing bracket through either the end bearing bracket's upper or lower slots to the left hand horizontal track angle using (2) 3/8" - 16 x 3/4" truss head bolts and (2) 3/8" - 16 nuts.

IMPORTANT: THE END BEARING BRACKET'S LOWER SLOTS ARE USED ON DOORS WITH 12" RADIUS TRACK; THE UPPER SLOTS ARE USED ON DOORS WITH 15" RADIUS TRACK.

SECURE THE END BEARING BRACKET TO THE JAMB USING ONE OF THE FOLLOWING SCENARIOS LISTED BELOW:

For wood jambs, using (3) 5/16" x 1-5/8" lag screws.

NOTE: Prior to fastening end bearing brackets into the door jamb, pilot drill using a 3/16" drill bit.

For steel jambs, using (3) 5/16" x 1" self drilling screws.

For pre-cast concrete, using (3) 3/8" x 3" sleeve anchors (not supplied).

NOTE: Products being installed to pre-cast or block must use a 3/8" x 3" sleeve anchor to attach the end bearing brackets to the building, as shown. Use the slots in the end bearing bracket as a drill template and drill a 3/8" hole (3-1/2" deep) and secure to anchor.

WARNING

DO NOT USE SLEEVE ANCHORS ON HOLLOW BLOCK.

Repeat the same process for the right hand side.

NOTE: This illustration shows 15" radius track with lag screws to Wood Jambs.

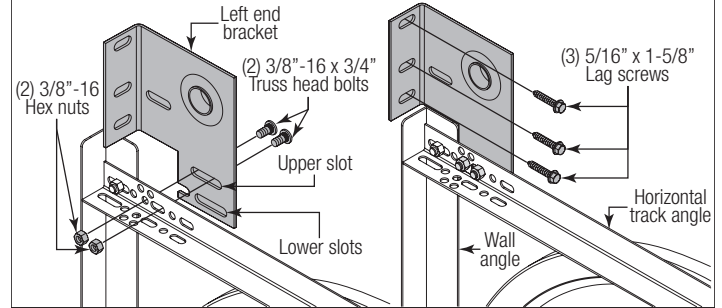

NOTE: This illustration shows 15" radius track with self drilling screws to Steel.

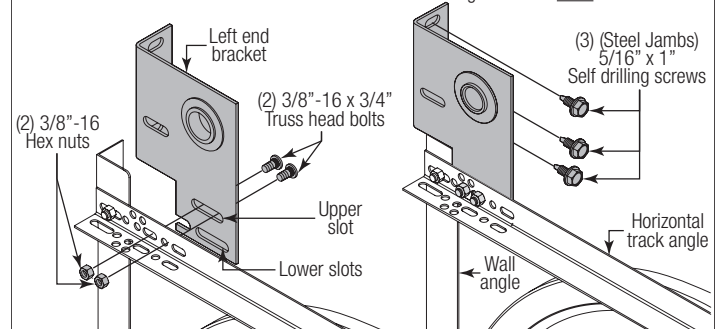

NOTE: This illustration shows 15" radius track with anchors to Concrete.

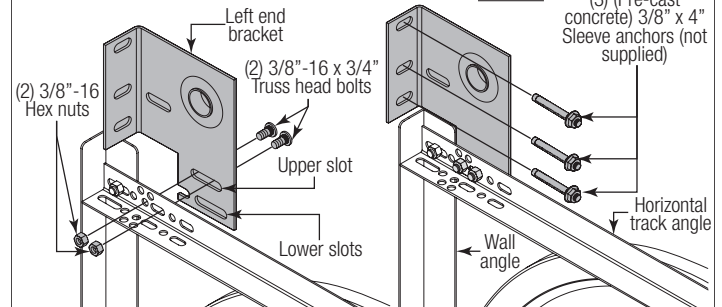

20

Attaching Center Bracket to Wall

NOTE: Refer to Package Contents / Breakdown of Parts, to determine which Center Bracket(s) came with your door.

NOTE: When attaching the center bracket(s) to the spring pads, it has to be at the same elevation as the bearing in the end bearing brackets.

NOTE: Additional center brackets may be required for doors with coupler assembly. Refer to Package Contents / Breakdown of Parts, to determine if you have a coupler assembly.

NOTE: If your door came with (4) or more springs, each of the outer springs mounting surface will need to be a minimum of 3" wide.

NOTE: If needed, measure the diameter of your springs. If you have a one piece shaft with 3-3/4" or larger diameter springs, they do not share center brackets and do not have a coupler assembly.

First, locate the center of the door. Mark a vertical pencil line on the mounting surface above the door, at the center. Measure from the center of the bearing, in one of the end bearing brackets, downwards, to the top of the door. Using that measurement, measure that distance upwards from the top of the door to the mounting surface and mark a horizontal pencil line

which intersects the vertical pencil line.

NOTE: On some single spring doors, the spring can be longer than half the opening width. If your spring is longer, then the center bracket must be mounted off center for the spring to fit properly. Measure spring length adding room for spring growth during winding, to determine appropriate center bracket location.

NOTE: Depending on the construction, different fasteners must be used.

FOR WOOD CONSTRUCTION: Align the edge of the center bracket with the vertical pencil line and the center of the center bracket with the horizontal pencil line; this is to ensure the torsion shaft is level between the center and end bearing brackets. Attach the center bracket to the mounting surface, using 5/16" x 1-5/8" lag screws.

NOTE: Drill 3/16" pilot holes into header for the lag screws.

FOR STEEL CONSTRUCTION: Secure each center bracket using (4) 5/16" x 1" self-drilling and tapping screws, as shown.

FOR PRE-CAST CONSTRUCTION: Secure each center bracket using (2) 1/2" x 3" sleeve anchors (by others). This installation will require the 1/2" anchors to be secured to the building and then secure the brackets to the anchors, as shown.

NOTE: Pre-Drill 1/2" pilot holes into the pre-cast for the 1/2" x 3" sleeve anchors.

FOR BLOCK CONSTRUCTION: Attach perforated angle 18" long to center bracket(s) using (2) 3/8" x 1-1/4" bolts and (2) 3/8" nuts. Chamfer angle to clear top section high arc. Secure center bracket(s) and perforated angle to block using (4) 3/8" x 2-1/2" sleeve anchors, as shown.

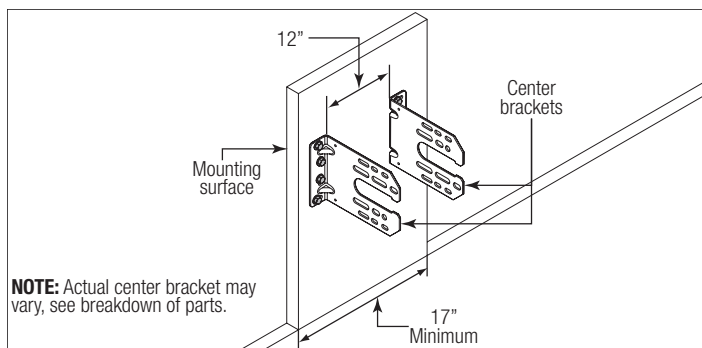

NOTE: Actual center bracket may vary, see breakdown of parts.

FOR ALTERNATE STEEL SPRING PAD APPLICATIONS:

IMPORTANT: DO NOT BOLT TWO 3-3/4" OR LARGER DIAMETER SPRINGS TO ONE CENTER BRACKET.

WARNING

DO NOT USE SLEEVE ANCHORS ON HOLLOW BLOCK.

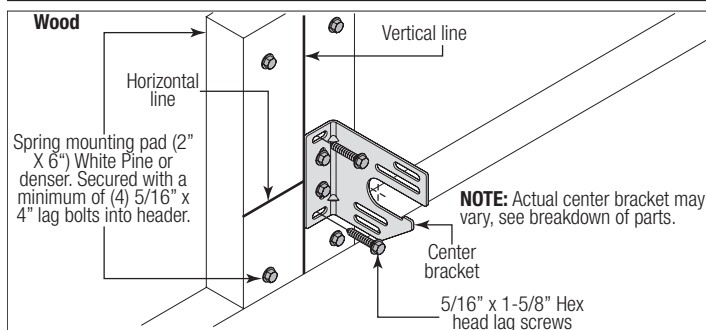

NOTE: Actual center bracket may vary, see breakdown of parts.

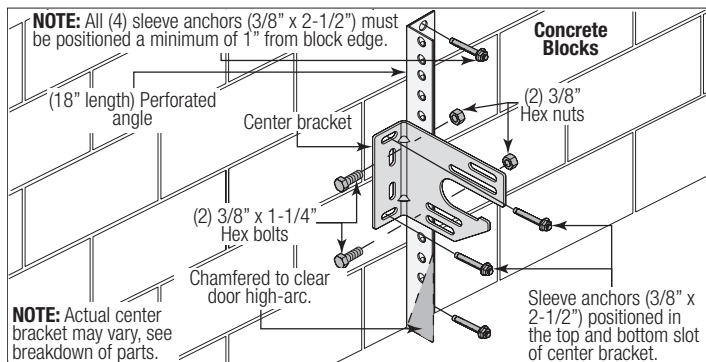

NOTE: Actual center bracket may vary, see breakdown of parts.

NOTE: Actual center bracket may vary, see parts breakdown.

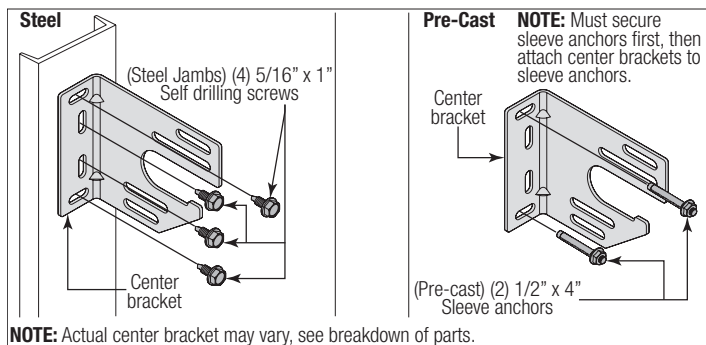

NOTE: Actual center bracket may vary, see breakdown of parts.

NOTE: Must secure sleeve anchors first, then attach center brackets to sleeve anchors.

WARNING

THESE SPRING MOUNTING TECHNIQUES ARE NOT SUPPORTED FOR 800-32 CABLE DRUMS. THESE INSTRUCTIONS ARE ALSO NOT APPLICABLE FOR 5750-120 CABLE DRUMS WITH 72" OR MORE HIGH-LIFT.

WARNING

MAXIMUM SPACING FOR DIMENSION "Y" IS 84" (7 FT.) THESE INSTRUCTIONS ARE NOT APPLICABLE FOR A SPAN GREATER THAN 84" ..

Maximum Door Size 9'0" x 9'0" (Maximum Door Weight 210 lb.)

Cut perforated angle (1-5/8" x 2-3/8" x 11 GA.) to Dim "Y". Thru-bolt top and bottom of angle to each girt using (4) 3/8" x 1-1/4" bolts and (4) 3/8" nuts. Thru-bolt center bracket to perforated angle using (3) 3/8" x 1-1/4" bolts and (3) 3/8" nuts, as shown.

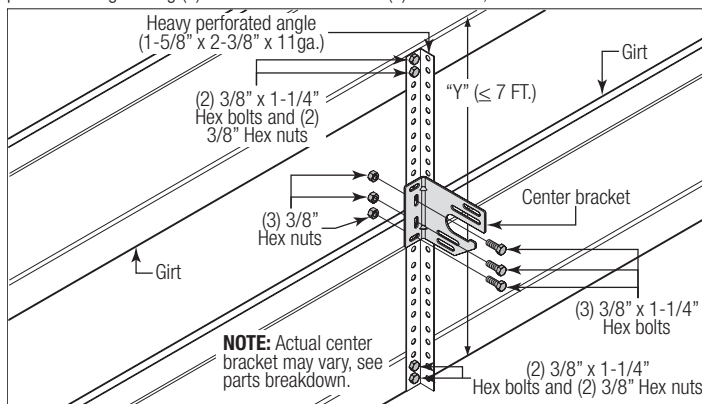

NOTE: Actual center bracket may vary, see parts breakdown.

Maximum Door Size 14'0" x 12'0" (Maximum Door Weight 400 lb.)

Cut (2) perforated angle (1-5/8" x 2-3/8" x 11 GA.) to Dim "Y". Thru-bolt top and bottom of each angle to each girt using (4) 3/8" x 1-1/4" bolts and (4) 3/8" nuts. Thru-bolt each center bracket to perforated angle using (3) 3/8" x 1-1/4" bolts and (3) 3/8" nuts, as shown.

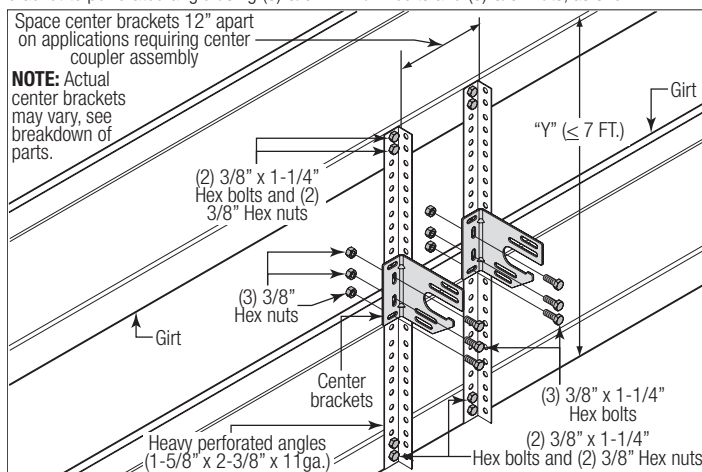

Maximum Door Size 14'-2" x 12'-1" (Maximum Door Weight 800 lb.)

Cut (2) pieces of perforated angle (1-5/8" x 2-3/8" x 11 GA.) to Dim "Y" and (2) more pieces at Dim "Y" minus 3". Bolt the angles together into a "Z" shape using (4) 3/8" x 1-1/4" bolts and (4) 3/8" nuts. Thru-bolt top and bottom of each "Z" shaped angle to each girt using (4)

3/8" x 1-1/4" bolts and (4) 3/8" nuts. Thru-bolt each center bracket to perforated angle assembly using (3) 3/8" x 1-1/4" bolts and (3) 3/8" nuts, as shown.

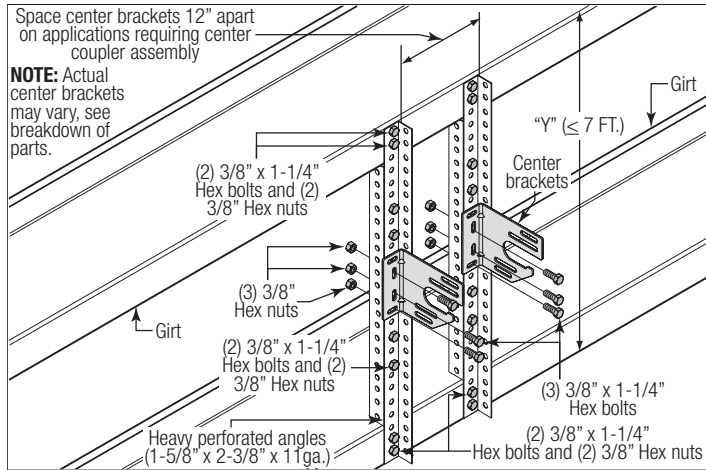

Double Springs Applications, Two Or Four Springs, 1 Piece Shaft, Up To 2-5/8" Springs

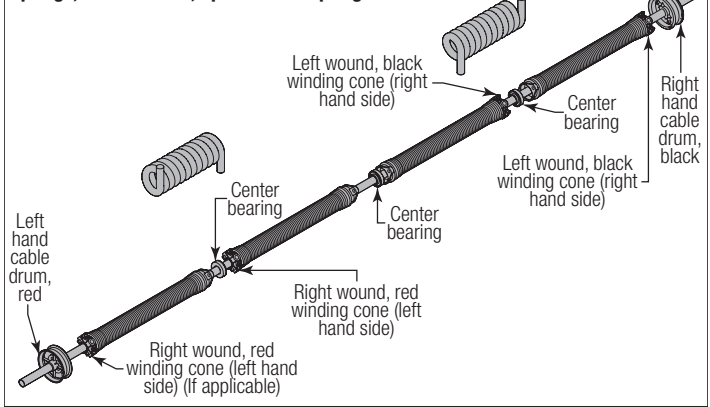

Single Spring Or Double Springs Applications, 1 Piece Shaft, 3-3/4" and 6" Springs

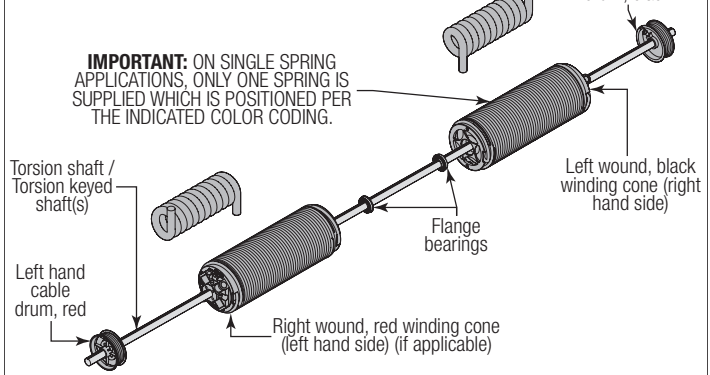

Double Springs Applications, 2 Piece Shafts, Two or 4 springs, up to 6" Springs.

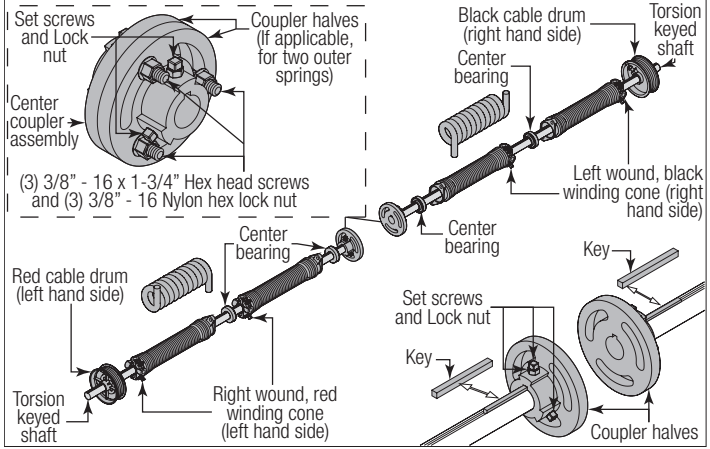

IF YOUR DOOR DOESN'T HAVE A COUPLER ASSEMBLY: With assistance, pick up the torsion spring assembly and slide one end of the torsion shaft / torsion keyed shaft through one end bearing bracket. Lay the middle of the torsion shaft / torsion keyed shaft into the center bracket. Slide the other end of the torsion shaft / torsion keyed shaft into the other end bearing bracket. Position the torsion shaft / torsion keyed shaft so that equal amounts of the shaft extend from each of the end bearing brackets.

NOTE: Position the torsion shaft so that equal amounts of the shaft extend from each end bearing bracket.

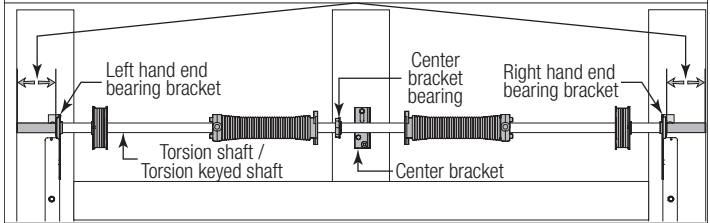

IF YOUR DOOR HAS A COUPLER ASSEMBLY: With assistance and starting on the left hand side of door, pick up the left hand torsion spring assembly and slide one end of the torsion keyed shaft through the end bearing bracket. Lay the other side of the torsion keyed shaft into the center bracket. Repeat the same process for the right hand torsion spring assembly. Position both torsion keyed shafts so that equal amounts of the shafts extend from each of the end bearing brackets.

21

Torsion Spring Assembly

IMPORTANT: RIGHT AND LEFT HAND IS ALWAYS DETERMINED FROM INSIDE THE BUILDING LOOKING OUT.

NOTE: Torsion spring assemblies can be of several configurations depending on your door size and door weight.

IMPORTANT: ON SINGLE SPRING APPLICATIONS, ONLY A LEFT HAND WOUND (BLACK WINDING CONE), WHICH GOES ON THE RIGHT HAND SIDE IS REQUIRED.

NOTE: Identify the torsion springs provided as either right hand wound (red winding cone), which goes on the LEFT HAND SIDE or left hand wound (black winding cone), which goes on the RIGHT HAND SIDE.

Facing the inside of the door and referencing the illustrations shown, lay the torsion shaft / torsion keyed shaft(s) on the floor.

NOTE: If your door came with (2) torsion keyed shafts, one torsion keyed shaft should be on the left hand side of the floor and the other torsion keyed shaft should be on the right hand side of the floor.

Lay the torsion spring(s) with the black winding cone and the black cable drum at the right end of the torsion shaft / torsion keyed shaft(s). Lay the torsion spring(s) with the red winding cone and the red cable drum at the left end of the torsion shaft / torsion keyed shaft(s).

NOTE: The set screws used on all torsion winding cones and cable drums are colored red. DO NOT identify right and left hand by the set screw color.

IF YOUR DOOR CAME WITH A COUPLER ASSEMBLY: Disassemble the coupler assembly by removing the (3) 3/8" - 16 x 1-3/4" hex head screws and the (3) 3/8" - 16 nylon hex lock nuts from the coupler halves. Loosen the set screws. Slide the flat edge of the coupler half flush with the side edge of the torsion keyed shaft. Insert (1) key into the slot of both the coupler halves and the slot in the torsion keyed shaft. Tighten the (2) set screws and the locking nut to secure the coupler half to the torsion keyed shaft, as shown. Repeat the same processes for the other coupler half.

NOTE: Tighten the set screws to 14 - 15 ft. lbs. of torque (once set screws contact the shaft, tighten set screws one full turn).

IMPORTANT: THE COUPLER HALVES, CENTER BEARING(S), TORSION SPRINGS, AND CABLE DRUMS MUST BE POSITIONED, AS SHOWN IN THE ILLUSTRATIONS.

Single Spring Or Double Springs Applications, 1 Piece Shaft, Up To 2-5/8" Springs

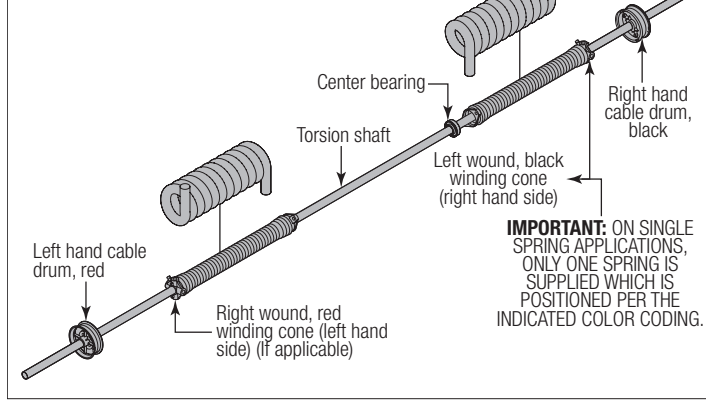

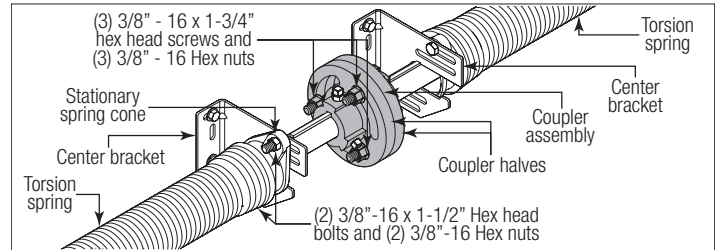
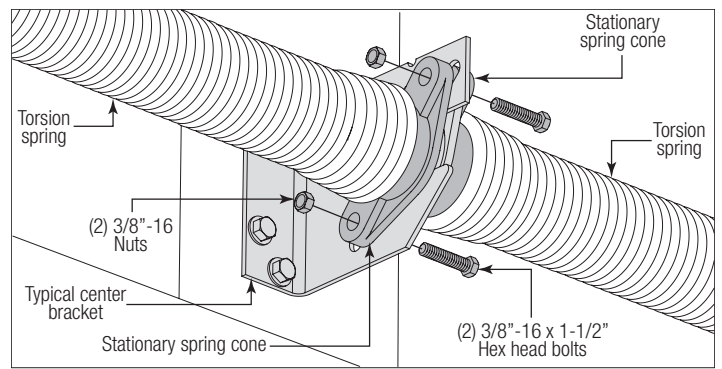
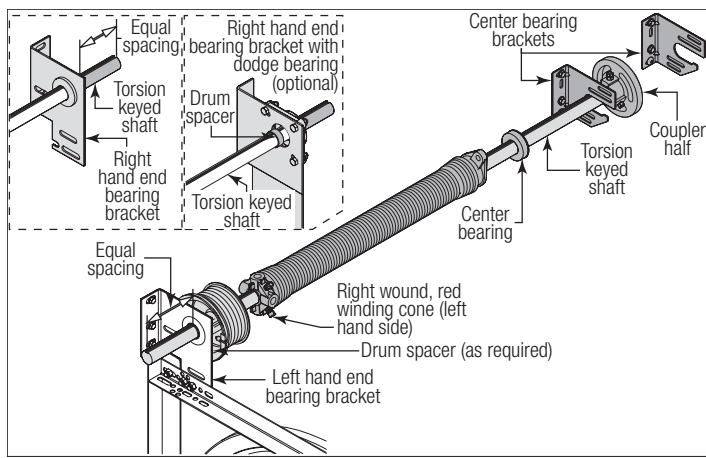

22

Attaching Springs to Center Bracket

NOTE: Refer to Package Contents / Breakdown of Parts, to determine which Center Bracket(s) came with your door.

NOTE: Refer to Package Contents / Breakdown of Parts, to determine if your door came with a coupler assembly.

IMPORTANT: THE SPRING WARNING TAG(S) SUPPLIED MUST BE SECURELY ATTACHED TO THE STATIONARY SPRING CONE(S) IN PLAIN VIEW. SHOULD A REPLACEMENT SPRING WARNING TAG BE REQUIRED, CONTACT WAYNE DALTON FOR FREE REPLACEMENTS.

NOTE: Measure the diameter of your springs. If your spring diameter is 3-3/4", the springs do not share center brackets. If your spring diameter is either 2" or 2-5/8", then two springs will share the same center bracket, unless a coupler assembly is provided.

IF YOU DON'T HAVE A COUPLER ASSEMBLY: Slide center bracket bearing into the spring. Align the stationary spring cone(s) with the holes in the center bracket. Secure the torsion spring(s) to the center bracket with (2) 3/8" - 16 x 1-1/2" hex head bolts and (2) 3/8" - 16 nuts.

IMPORTANT: NEVER USE MORE THAN ONE BEARING WHEN ATTACHING TWO SPRINGS TO ONE CENTER BRACKET.

IF YOU HAVE A COUPLER ASSEMBLY: Slide center bracket bearing into the spring. Align the stationary spring cone with the holes in the center bracket. Secure the torsion spring to the center bracket with (2) 3/8" - 16 x 1-1/2" hex head bolts and (2) 3/8" - 16 nuts. Repeat the same process for the other center bearing bracket.

At the middle of the two center bearing brackets, re-assemble the coupler assembly by loosely fastening the coupler halves together using the (3) 3/8" - 16 x 1-3/4" hex head screws, (6) 3/8" washers, (3) 3/8" lock washers and the (3) 3/8" - 16 hex nuts, previously removed.

NOTE: Ensure both torsion keyed shafts have equal amounts of the shafts extending from each end bearing bracket.

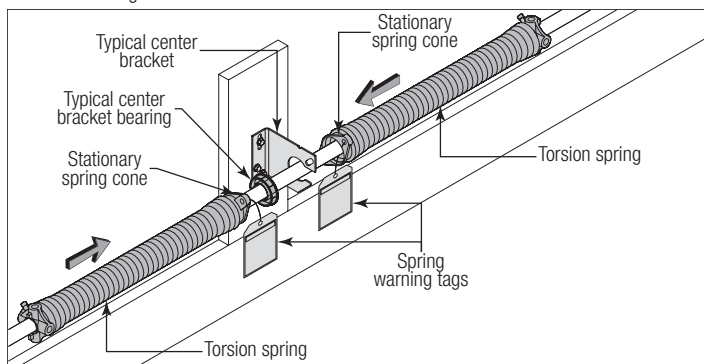

NOTE: Refer to Package Contents / Breakdown of Parts, to determine which Center Bracket(s) came with your door.

NOTE: Refer to Package Contents / Breakdown of Parts, to determine if your door came with a coupler assembly.

IMPORTANT: THE SPRING WARNING TAG(S) SUPPLIED MUST BE SECURELY ATTACHED TO THE STATIONARY SPRING CONE(S) IN PLAIN VIEW. SHOULD A REPLACEMENT SPRING WARNING TAG BE REQUIRED, CONTACT WAYNE DALTON FOR FREE REPLACEMENTS.

FOR SPRINGS UP TO 3-3/4" ID AND IF YOU DON'T HAVE A COUPLER ASSEMBLY: Slide center bearing into the spring (if applicable). Align the stationary spring cone(s) with the holes in the center bracket assembly. Secure the torsion spring(s) to the center bracket assembly with (2) 3/8" - 16 x 1-1/2" hex head bolts and (2) 3/8" - 16 nuts.

IF YOU HAVE A COUPLER ASSEMBLY: Slide the center bearing into the spring. Align the stationary spring cone with the holes in the center bearing bracket.

NOTE: Prior to attaching the torsion spring(s) to the center bracket(s), the torsion shaft / torsion keyed shafts have to be at the same elevation as the bearing in the end bearing brackets. Slide the torsion shaft / torsion keyed shafts out to the correct shaft centerline from the jambs before tightening the spring assembly fasteners.

FOR SPRINGS UP TO 3-3/4" ID: Secure the torsion spring to the center bracket with (2) 3/8" - 16 x 1-1/2" hex head bolts and (2) 3/8" - 16 nuts. Repeat the same process for the other center bearing bracket.

FOR 6" AND DUPLEX SPRINGS: Secure the torsion spring and the flange bearing to the center bracket using (2) 3/8" - 16 x 1" Hex head bolts, as shown.

WARNING

FOR DUPLEX SPRINGS, YOU MUST ENSURE THE ASSEMBLY BOLTS GO THROUGH THE CENTER BRACKET AND INNER SPRING CONE AND THREAD INTO THE OUTER SPRING CONE AS SHOWN. FAILURE TO ENSURE THE BOLTS ARE SECURING BOTH THE INNER AND OUTER SPRING CONES TO THE CENTER BRACKET CAN RESULT IN SUDDEN SPRING TENSION RELEASE, CAUSING SEVERE OR FATAL INJURY.

At the middle of the two center bearing brackets, loosely re-assemble the coupler assembly by fastening the coupler halves together using the (3) 3/8" - 16 x 1-3/4" hex head screws and the (3) 3/8" - 16 nylon hex lock nuts, as shown.

NOTE: Ensure both torsion keyed shafts have equal amounts of the shafts extending from each end bearing brackets.

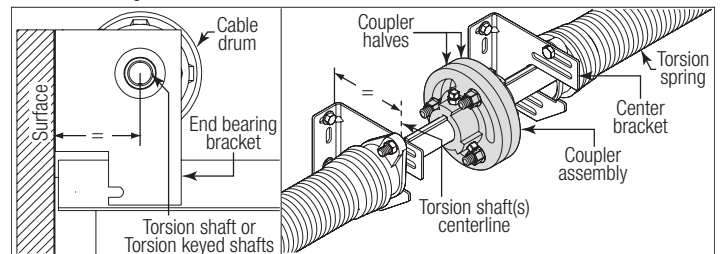

Up To 3-3/4" Springs Applications

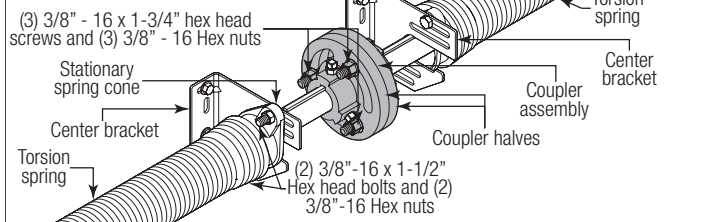

6" Springs Applications

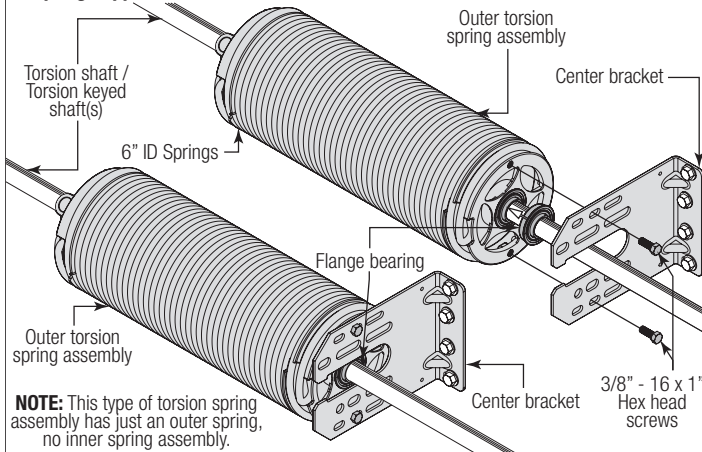

6" Duplex Springs Applications

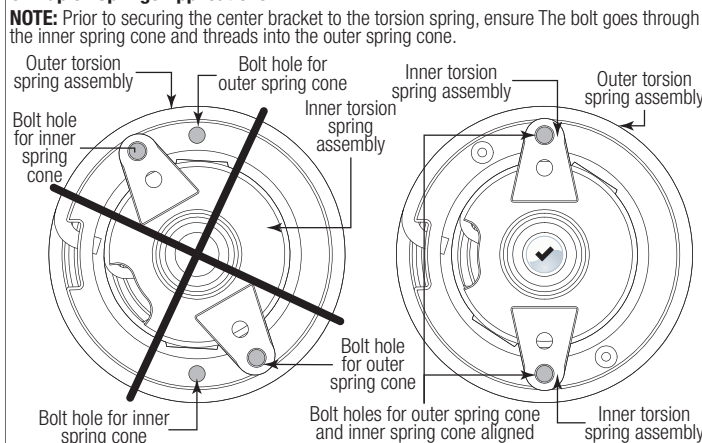

6" Duplex Springs Applications

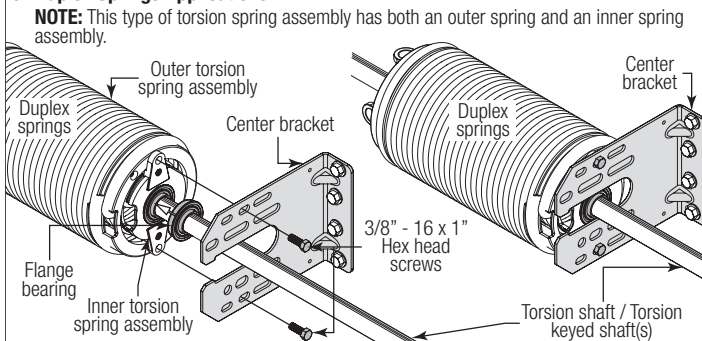

terminate at the 3 o'clock position.

NOTE: If you have torsion keyed shaft(s), insert (1) key into the slot of both the cable drum and the slot in the torsion keyed shaft, as shown.

FOR SPRINGS UP TO 3-3/4" ID: Tighten the (2) set screws in the drum to 14 - 15 ft. lbs. of torque (once set screws contact the shaft, tighten screws one full turn).

FOR 6" AND DUPLEX SPRINGS: Tighten the (4) set screws in the drum to 25 ft. lbs. of torque (once set screws contact the shaft, tighten screws 1/2 to 1 full turn).

At the middle of the two center bearing brackets, loosen the (3) 3/8" - 16 x 1-3/4" hex head screws and the (3) 3/8" - 16 nylon hex lock nuts from the coupler assembly (if applicable).

Rotate the left hand drum and torsion shaft until counterbalance lift cable is taut. Now attach locking pliers to the torsion shaft and brace locking pliers up against jamb to keep counterbalance lift cable taut. Repeat for right hand side.

At the middle of the two center bearing brackets, tighten the (3) 3/8" - 16 x 1-3/4" hex head screws and the (3) 3/8" - 16 nylon hex lock nuts from the coupler assembly (if applicable).

IMPORTANT: INSPECT EACH COUNTERBALANCE LIFT CABLE MAKING SURE IT IS SEATED PROPERLY ONTO THE CABLE DRUM AND THAT BOTH COUNTERBALANCE LIFT CABLES HAVE EQUAL TENSION.

CHECK COUNTERBALANCE LIFT CABLES FOR EQUAL TENSION:

1. Attach locking pliers to track above top roller.
2. Grasp cable at approximate mid-door height location.
3. Draw cable toward you about 1/2" to 1" and release, noting the response of the cable.
4. Repeat above steps for other cable.
5. Adjust cable tension as needed until right and left cables both respond the same.

Once the counterbalance cables are set and if applicable tighten the coupler assembly together by tightening the (3) 3/8" - 16 nylon hex nuts to secure the coupler halves together.

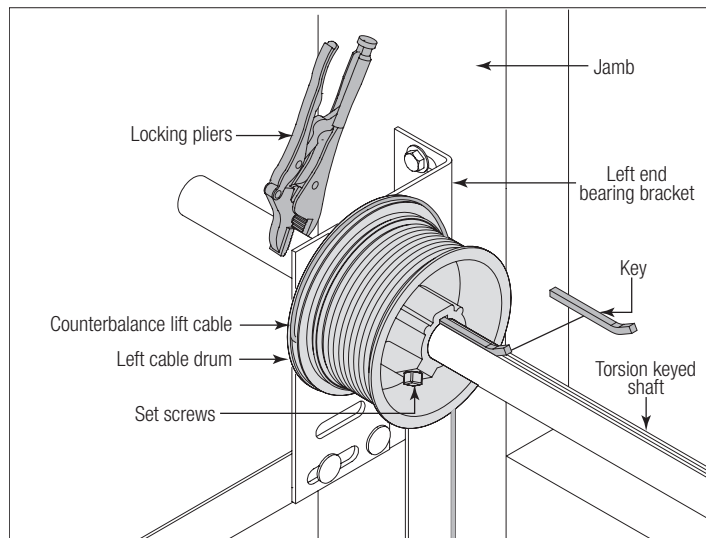
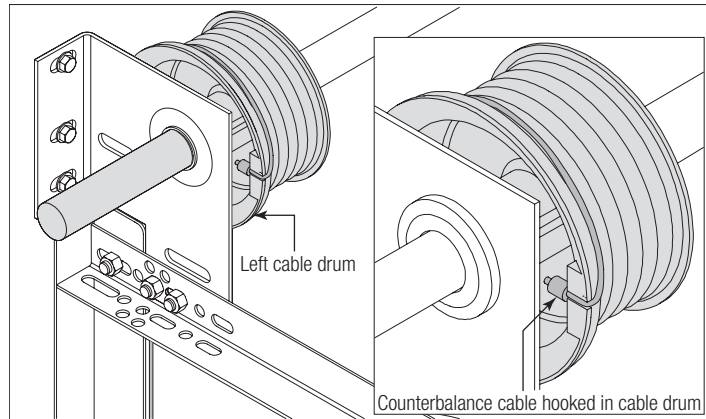

23

Attaching Counterbalance Lift Cables

Starting on the left hand side, thread the counterbalance lift cable up and around the front side of the left hand cable drum.

IMPORTANT: VERIFY THAT THERE ARE NO OBSTRUCTIONS IN THE TRAVEL PATH OF THE DOOR SECTIONS OR COUNTERBALANCE LIFT CABLES.

NOTE: Always assemble the left hand cable and cable drum first to help maintain equal cable tension on both sides of the door.

Hook the counterbalance lift cable into the left hand cable drum. Slide the left hand cable drum up against the left hand end bearing bracket / spacer. Counterbalance lift cable should

NOTE: Prior to securing the cable drum to the torsion shaft / torsion keyed shaft, position the cable drum tight up against the drum spacer.

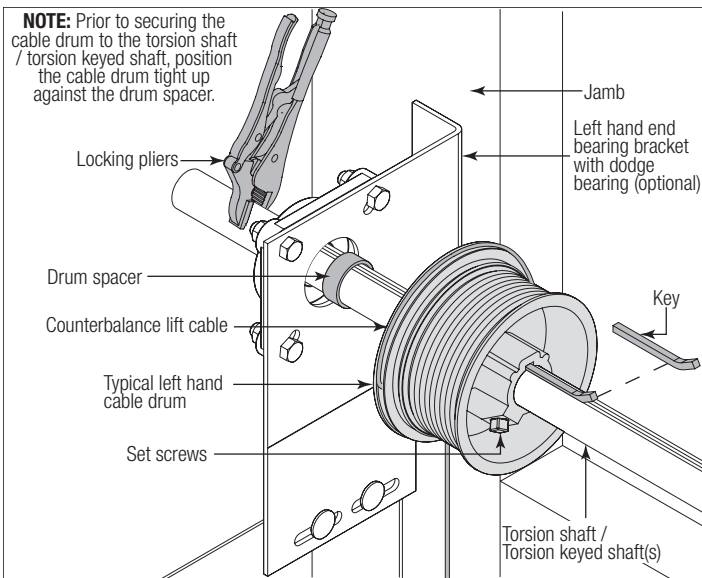

24

Chalking Torsion Spring(s)

NOTE: If your springs have stenciling, then skip this step.

Draw a chalk line horizontally along the center of the torsion spring coil(s). As the torsion spring is wound, the chalk line will create a spiral. This spiral can be used to count and determine the number of turns that are applied on the torsion spring.

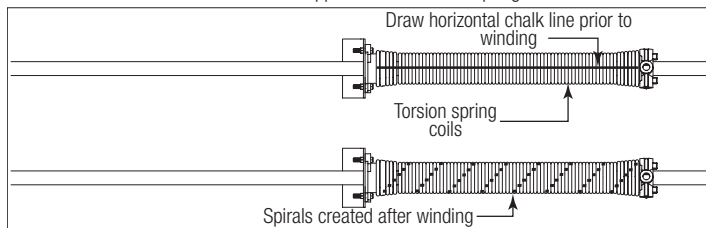

25

Securing Door for Spring Winding

With the door in the fully closed position, place locking pliers onto both vertical tracks just above the third track roller. This is to prevent the garage door from rising while winding springs.

NOTE: Check the following before attempting to wind torsion spring(s):

- Counterbalance lift cables are secured at bottom corner brackets.
- Counterbalance lift cables are routed unobstructed to cable drums.
- Counterbalance lift cables are correctly installed and wound onto cable lift drums.
- Counterbalance lift cables are taut and have equal tension on both sides.
- Cable lift drums are against end bearing brackets and set screws are tight.
- Torsion spring or springs are installed correctly.
- Review the label attached to the spring warning tag, to determine number of spring turns required.

NOTE: Door **MUST** be closed and locked when winding or making any adjustments to the torsion spring(s).

WARNING

FAILURE TO ENSURE DOOR IS IN A CLOSED POSITION AND TO PLACE LOCKING PLIERS ONTO VERTICAL TRACK CAN ALLOW DOOR TO RISE AND CAUSE SEVERE OR FATAL INJURY.

Winding Bars (Steel Rods)	Size Of Winding Bar (Inches)	Spring Inner Diameter Used On
█	1/2" dia. x 18"	2" and 2-5/8"
█	5/8" dia. x 24"	3-3/4"

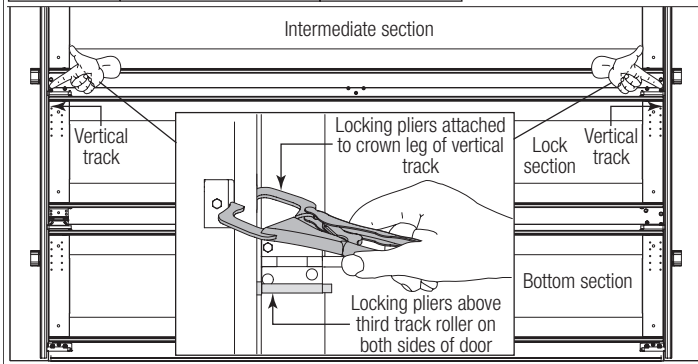

26

Winding Spring(s)

WARNING

WINDING SPRING IS AN EXTREMELY DANGEROUS PROCEDURE AND SHOULD BE PERFORMED ONLY BY A TRAINED DOOR SYSTEM TECHNICIAN USING PROPER TOOLS AND INSTRUCTIONS.

WARNING

USE ONLY SPECIFIED WINDING BARS, AS STATED IN STEP SECURING DOOR FOR SPRING WINDING. DO NOT SUBSTITUTE WITH SCREWDRIVERS, PIPE, ETC. OTHER TOOLS MAY FAIL OR RELEASE FROM THE SPRING CONE AND CAUSE SEVERE OR FATAL INJURY.

WARNING

PRIOR TO WINDING THE SPRING, ENSURE YOU'RE WINDING IN THE PROPER DIRECTION AS SHOWN BELOW. OTHERWISE THE SPRING FITTING MAY RELEASE FROM SPRING AND RESULT IN SEVERE OR FATAL INJURY.

Position a ladder slightly to the side of the spring so that the winding cone is easily accessible, and so your body is not directly in line with the winding bars.

Check the label attached to the spring warning tag for the required number of complete turns to balance your door.

HOW TO WIND TORSION SPRINGS:

- Insert one winding rod snugly into winding cone, to full socket depth
- Maintaining a tight grip on the winding rod rotate it slowly in the proper direction, as shown below.
- If there is any slippage of the winding rod in the winding cone socket, reverse the direction of winding and return the cone to its original position. Remove the winding rod from the winding cone socket. Reseat the winding rod in the socket. Start over at Step #1.
- When the winding rod is vertical above the winding cone, insert another winding rod into one of the other sockets, being careful to seat it snugly and at full socket depth.
- Hold the spring with the second winding bar, and remove the first.
- Repeat Steps #2 through #5 until the complete turns have been applied.

FOR SPRINGS UP TO 3-3/4" ID: Securely hold the winding rod while tightening the 2 set screws in the winding cone to 14 - 15 ft. lbs. of torque (once set screws contact the torsion shaft, tighten screws one full turn).

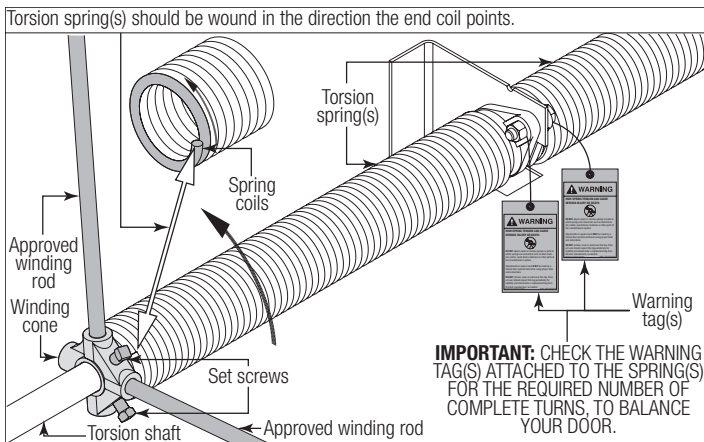

FOR 6" AND DUPLEX SPRINGS: Securely hold the winding rod while tightening the 4 set screws in the winding cone to 25 ft. lbs. of torque (once set screws contact the torsion keyed shaft, tighten screws 1/2 to 1 full turn).

IMPORTANT: IF YOU HAVE TORSION KEYED SHAFT(S), ONE OF THE SET SCREWS WILL NEED TO BE TIGHTENED INTO THE KEYWAY OF THE TORSION KEYED SHAFT(S).

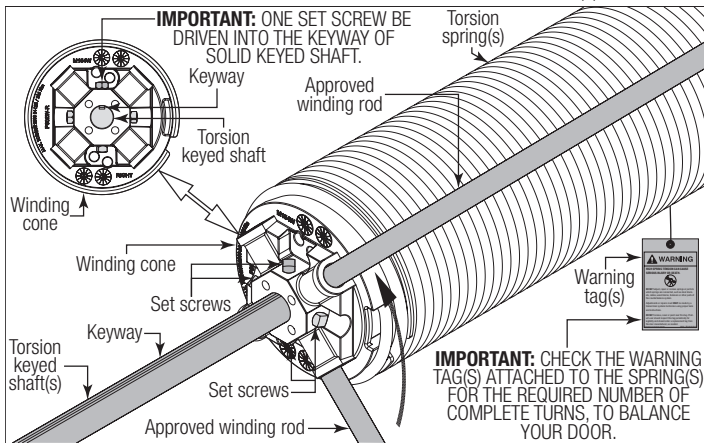

After the torsion spring is secure, use the winding rod to apply pressure in the opposite direction to ensure the set screws are securely fixed to the torsion shaft.

Carefully remove winding rod from winding cone. Repeat for remaining springs, if applicable. While holding the door down to prevent it from raising unexpectedly in the event the spring(s) were over-wound, carefully remove the locking pliers from the torsion shaft and vertical tracks.

NOTE: If you have a coupler assembly, it may be necessary to loosen and retighten the (3) 3/8" - 16 x 1-3/4" hex head screws and the (3) 3/8" - 16 nylon hex lock nuts assembly bolts to equalize the cable tension on both sides of the door.

Adjustments to the number of turns stated may be necessary. If door rises off floor under spring tension alone, reduce spring tension until door rests on the floor. If the door is hard to rise or drifts down on its own, add spring tension.

NOTE: An unbalanced door such as this can cause garage door opener operation problems.

WARNING

DO NOT OPEN DOOR UNTIL STEP REAR BACK HANGS IS COMPLETED.

27

Attaching Rear Back Hangs

IMPORTANT: HOLD THE DOOR DOWN TO PREVENT IT FROM RISING UNEXPECTEDLY IN THE EVENT THE SPRING(S) WERE OVER-WOUND AND CAUTIOUSLY REMOVE LOCKING PLIERS FROM VERTICAL TRACKS.

Raise the door until the top section and half of the next section are in the horizontal track radius. Do not raise door any further since rear of horizontal tracks are not yet supported.

WARNING

RAISING DOOR INTO THE LOOSE HORIZONTAL TRACKS CAN RESULT IN DOOR FALLING AND CAUSE SEVERE OR FATAL INJURY.

Clamp a pair of locking pliers onto the vertical tracks just above the second track roller on one side, and just below the second track roller on the other side. This will prevent the door from raising or lowering while installing the rear back hangs.

Using the chart below, select the appropriate perforated angle (may not be supplied). Fabri-

cate and install rear back hangs, as shown.

Perforated Angle Gauge Weight Limitations:	
Perforated Angle Gauge	Door Balance Weight
2" x 2" x 12 Gauge	Less Than 800 lbs.
1-1/4" x 1-1/4" x 13 Gauge	Less Than 305 lbs.
1-1/4" x 1-1/4" x 15 Gauge	Less Than 220 lbs.
1-1/4" x 1-1/4" x 16 Gauge	Less Than 175 lbs.

NOTE: If an opener is installed, position horizontal tracks one hole above level when securing it to the rear back hangs.

WARNING

MAKE SURE BACK HANGS ARE BRACED SUFFICIENTLY TO RESIST ANY MOTION DURING SPRING APPLICATION AND DOOR TRAVEL. IF BACK HANGS PIVOT OR DEFLECT, ADD REINFORCEMENT UNTIL THEY REMAIN FIRM AND STATIONARY. ANY BACK HANG THAT IS BENT MUST BE REPLACED.

WARNING

KEEP HORIZONTAL TRACKS PARALLEL AND WITHIN 3/4" TO 7/8" FROM DOOR EDGE, OTHERWISE DOOR COULD FALL, RESULTING IN SEVERE OR FATAL INJURY.

NOTE: Doors heights over 8'0" or door widths over 11'0", require an additional set of rear center back hangs to be installed and located at the middle of the horizontal tracks, see breakdown of parts.

Based on your door width and door heights and using perforated angle (may not be supplied), (2) 5/16" x 1-5/8" hex head lag screws and (3) 5/16" bolts with nuts (may not be supplied), fabricate rear center back hangs for the horizontal tracks, for the following:

FOR ITEM J2, (SEE BREAKDOWN OF PARTS): The Rear Center Back Hang Assemblies are to be used for all doors over 11'0" door height and over 14'0" door width. One Rear Center Back Hang Assembly, per side.

FOR ITEM J3, (SEE BREAKDOWN OF PARTS): The Rear Center Back Hang Assemblies are to be used for all doors over 16'0" door height. Two Rear Center Back Hang Assemblies, per side.

Measure and drill a 3/8" diameter hole through the center length of the horizontal track, as shown. Attach the rear center back hangs to the horizontal tracks with (1) 3/8" Truss head bolt and (1) 3/8" nut (may not be supplied).

IMPORTANT: DO NOT SUPPORT THE WEIGHT OF THE DOOR ON ANY PART OF THE REAR BACK HANGS THAT CANTILEVERS 4" OR MORE BEYOND A SOUND FRAMING MEMBER.

NOTE: If rear back hangs are to be installed over drywall, use (2) 5/16" x 2" hex head lag screws and make sure lag screws engage into solid structural lumber.

WARNING

FAILURE TO ASSEMBLE AND ATTACH REAR BACK HANGS PROPERLY ACCORDING TO THE ABOVE INSTRUCTIONS MAY RESULT IN DOOR FALLING WHEN RAISED, CAUSING SEVERE OR FATAL INJURY.

NOTE: Perforated angle must be attached to sound framing members and **nails should not be used.**

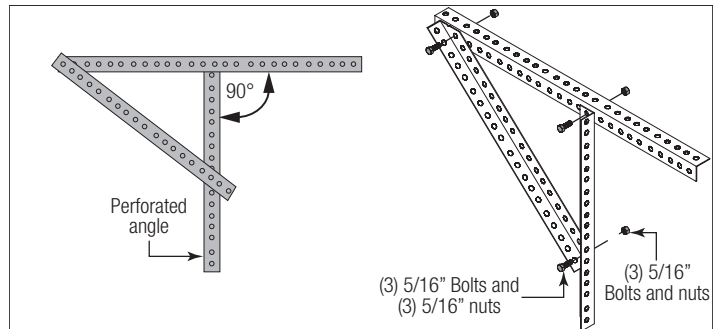

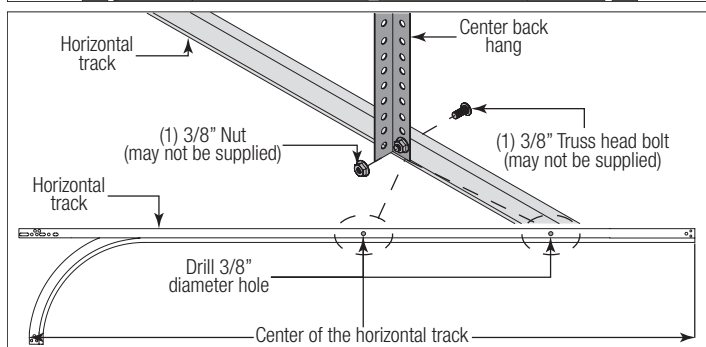
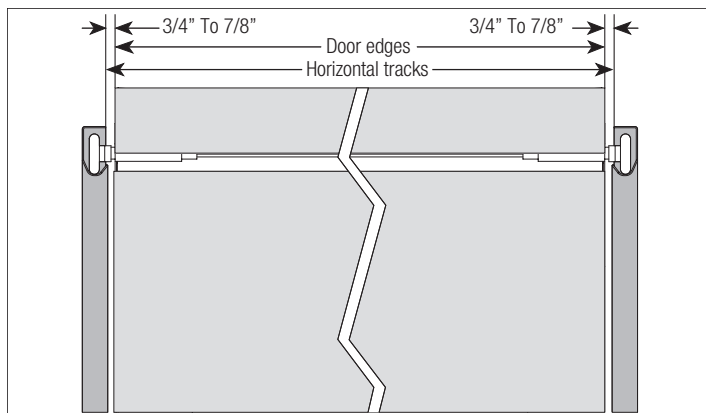
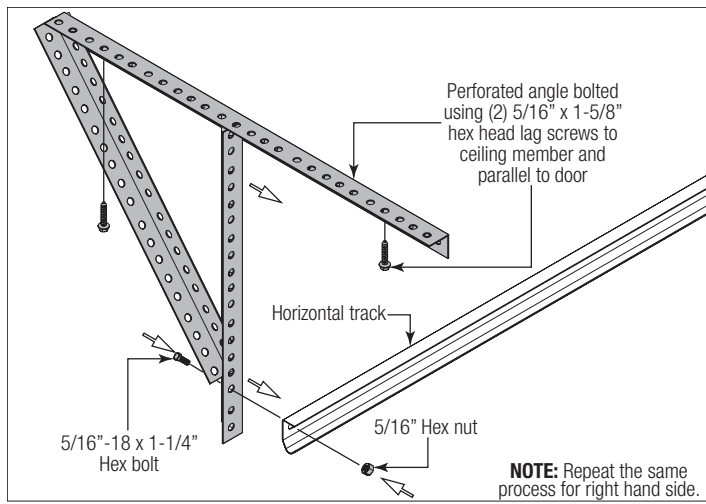

28

Cable Keepers

NOTE: If you don't have cable keepers, then skip this step. Refer to Step 4 Attaching Cable Keepers, to determine if you have cable keepers installed.

IMPORTANT: CABLE KEEPERS ARE INTENDED TO HELP PREVENT COUNTERBALANCE LIFT CABLES FROM COMING OFF CABLE DRUMS ON MANUALLY OPERATED DOORS. ADDITIONAL CABLE TENSIONING PROVISIONS MAY BE REQUIRED FOR MOTOR OPERATED DOORS.

Rotate arm up and hook around counterbalance lift cable, letting the cable keeper arm pull against the counterbalance lift cable, keeping it taut, as shown. Next, close the hook to prevent the counterbalance lift cables from coming out.

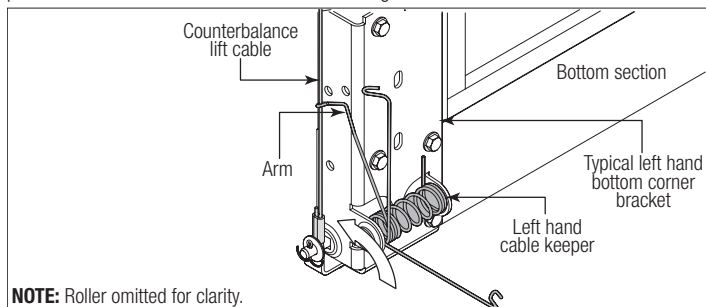

29

Attaching Weather Seal

NOTE: If you don't have weather seals, then skip this step. Refer to Package Contents / Breakdown of Parts, to determine if you have weather seals.

Permanently attach the weatherstrips on both door jambs and header. The weatherstrips were temporarily attached in Preparing the Opening, in the pre-installation section of this manual.

NOTE: When permanently attaching the weatherstrips to the jambs, avoid pushing the weatherstrips too tightly against the face of door.

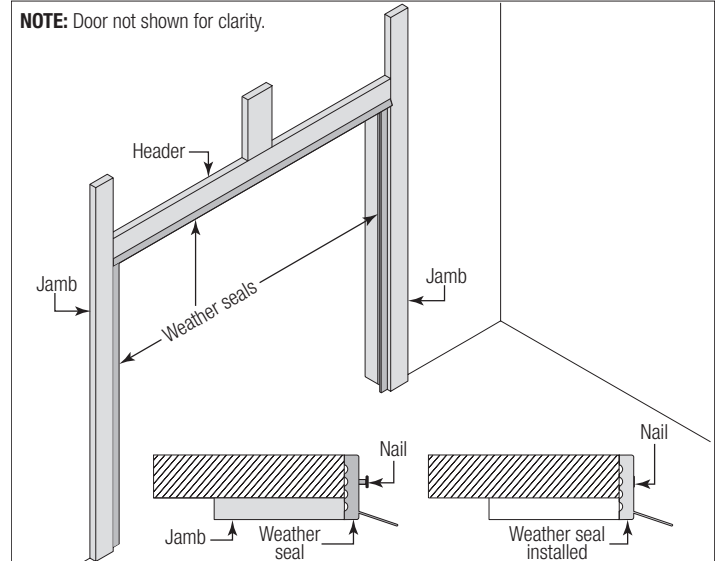

30

Balancing Door

Remove locking pliers. Lift door and check its balance. Adjustments to the required number of spring turns stated may be necessary. If door rises off floor more than 2 ft. under spring tension alone, reduce spring tension. If the door is hard to rise or drifts down on its own, add spring tension. A poorly balanced door can cause garage door operator problems.

To adjust spring tension, fully close door. Apply locking pliers to track above third track roller. Place locking pliers on torsion shaft, as shown in Step Attaching Counterbalance Lift Cables. Insert a winding rod into the winding cone. Push upward on the winding rod slightly while carefully loosening the set screws in the winding cone.

IMPORTANT: BE PREPARED TO SUPPORT THE FULL FORCE OF THE TORSION SPRING ONCE THE SET SCREWS ARE LOOSE.

Carefully adjust spring tension 1/4 turn. Retighten both set screws to 14-15 ft. lbs. of torque in the winding cone and repeat for the other side. Recheck door balance and re-adjust spring tension if needed.

IMPORTANT: DO NOT ADJUST MORE THAN 1 TURN FROM THE RECOMMENDED NUMBER OF TURNS.

If the door still does not operate easily, lower the door into the closed position, unwind spring(s) completely, and recheck the following items:

- 1.) Is the door level?
- 2.) Are the torsion shaft and flag angles / angle mount level and plumb?
- 3.) Does the distance between the flag angles / angle mount equal door width plus 3-3/8" to 3-1/2"?
- 4.) Do the counterbalance lift cables have equal tension? Adjust if necessary.
- 5.) Rewind the spring(s).
- 6.) Make sure door is not rubbing on jambs.

IMPORTANT: IF DOOR STILL DOES NOT BALANCE PROPERLY, THEN CONTACT A TRAINED DOOR SYSTEM TECHNICIAN.

Door Arm Hookup

NOTE: If you don't have a drawbar operator bracket, then skip this step. Refer to Illustrations shown below, Package Contents or Breakdown of Parts, to determine which drawbar operator bracket you have.

Align hole in the door arm with holes in drawbar operator bracket tabs / perforated angles, as shown. Attach with (1) 5/16" hex bolt and 5/16" hex nut (supplied by others).

For doors less than 16'3" wide and not exceeding 160 sq. ft.

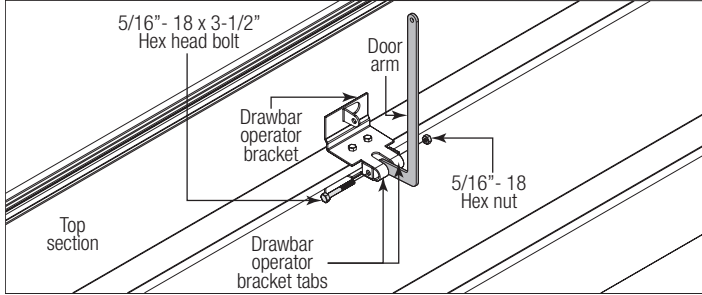

For doors over 16'2" wide through 20'2" and not exceeding 240 sq. ft., two drawbar operator brackets requires to be attached together with perforated angles.

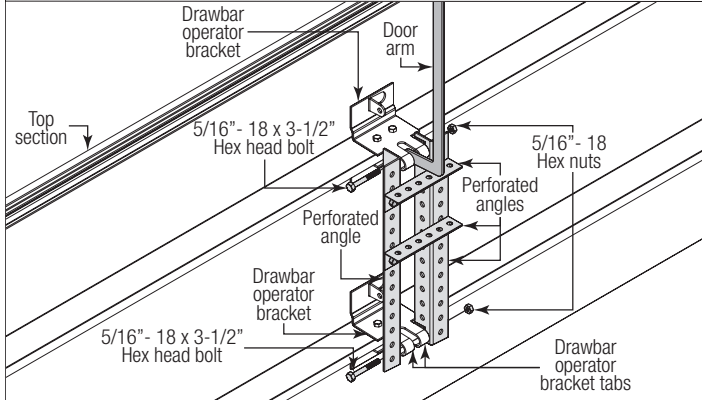

Doors over 20'2" through 25'2" wide and not exceeding 400 sq. ft., requires one 38" drawbar operator bracket.

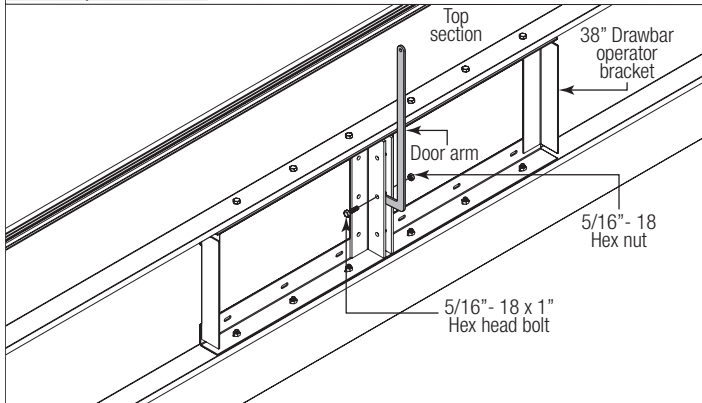

Doors over 25'2" wide and any door height, requires two 38" drawbar operator brackets.

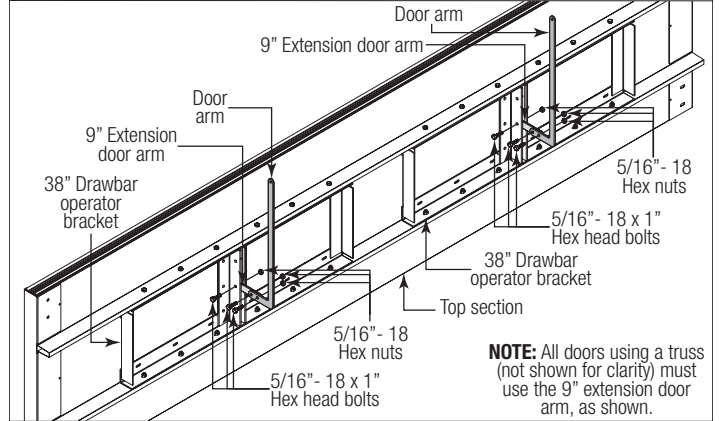

NOTE: All doors using a truss (not shown for clarity) must use the 9" extension door arm, as shown.

Inside Lock

Install the inside lock on the second section of the door. Secure the lock to the section with (4) 1/4" - 20 x 11/16" self drilling screws. Square the lock assembly with the door section, and align with the square hole in the vertical track. The inside lock should be spaced approximately 1/8" away from the section edge.

IMPORTANT: INSIDE LOCK(S) MUST BE REMOVED OR MADE INOPERATIVE IN THE UNLOCKED POSITION IF AN OPERATOR IS INSTALLED ON THIS DOOR.

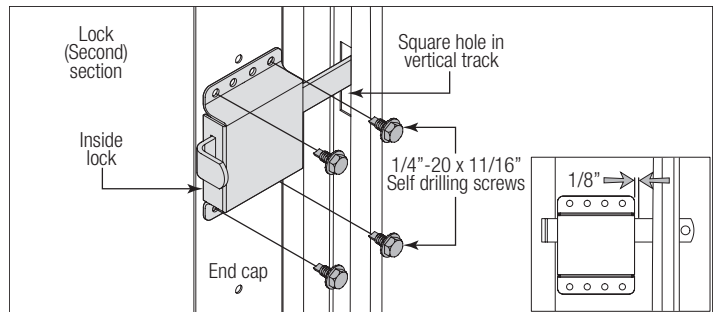

Lock Bar

IMPORTANT: LOCK MUST BE REMOVED OR MADE INOPERATIVE IN THE UNLOCKED POSITION IF AN OPERATOR IS INSTALLED ON THIS DOOR.

FOR SINGLE LOCK BAR: On the inside of the lock section, vertically align the middle of the lock plate "12-1/2" from the edge of the section and in between the ribs.

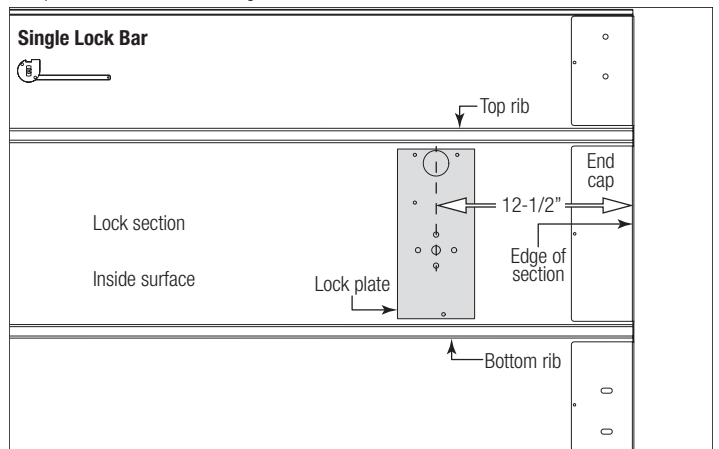

FOR DOUBLE LOCK BAR: On the outside of the lock section, align the double lock bar on the surface. With the double lock bar in the appropriate position, measure from in between the panels to the edge of the section. Using the measurement and from the inside of the lock section, measure from the same edge of the section inward and place a vertical mark on the inside of the section. Vertically align the middle of the lock plate with the vertical mark and in between both ribs, as shown.

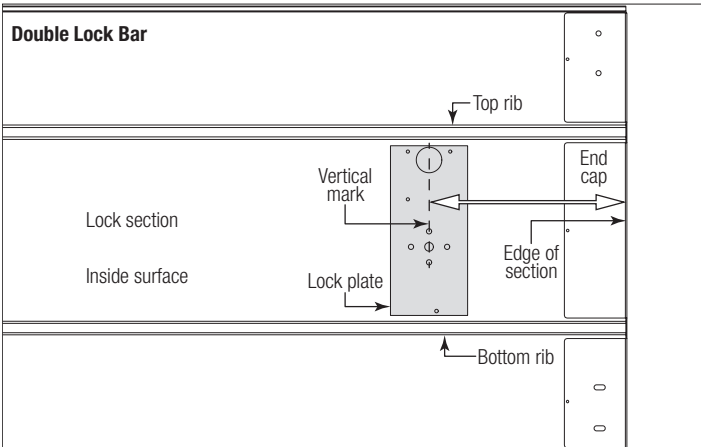
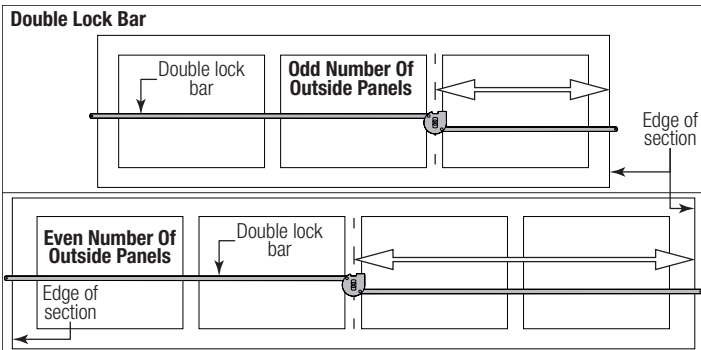

Using the holes in the lock plate as a template, mark the (4) hole locations onto the section surface. Drill 1/4" diameter holes straight through the entire section at each marked location. Starting with the top hole first and working downwards, enlarge the top hole to 1-1/4" diameter all the way thru the lock section, as shown/

Next enlarge the second and the fourth holes to 3/8" diameter all the way thru the lock section, as shown. Next enlarge the third hole on the inside surface of the lock section to 7/16" diameter without drilling thru the outer skin of the door.

CAUTION
 BE CAREFUL TO KEEP DRILL STRAIGHT WHEN PRE-DRILLING. SECTION DAMAGE CAN RESULT FROM FAILURE TO KEEPING THE DRILL STRAIGHT.

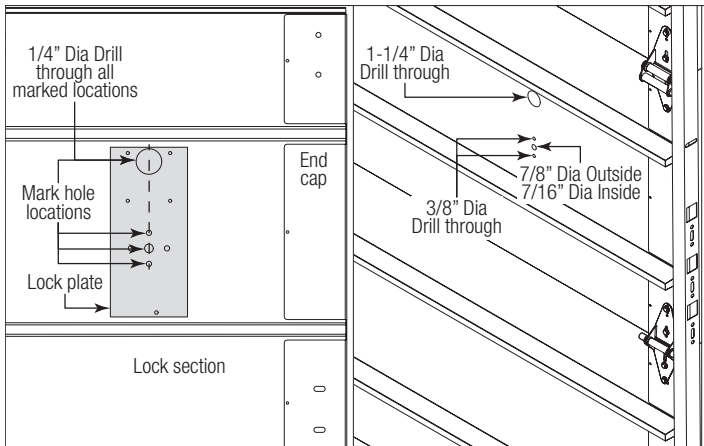

From the outside of the lock section, slide the appropriate spaced onto the outside handle. Insert the outside handle (shank first) into the section. From the inside of the section, secure the outside handle to the section using (2) #10 x 24 x 1-1/2" phillips head machine screws. Next, slide the lock disk and the inside handle onto the shank of the outside handle. Secure the inside handle over shank of the outside handle using a push nut.

NOTE: Use a short piece of 7/16" to 1/2" ID steel pipe to tap push nut onto shank.

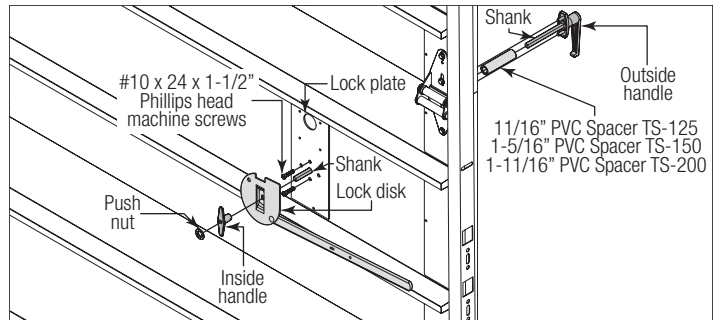

From the inside of the section, secure the rim cylinder plate to the section using (2) #12 x 1-7/8" pan head screws, broken to correct length.

Next on the outside of the lock section, slide the appropriate trim ring onto the rim cylinder. Insert the rim cylinder (stem first) into the section. From the inside of the section, secure the rim cylinder plate to the section using (2) #12 x 1-7/8" pan head screws broken to correct length.

Position the night latch to the lock plate using (4) #8 - 32 x 1/2" self tapping screws.

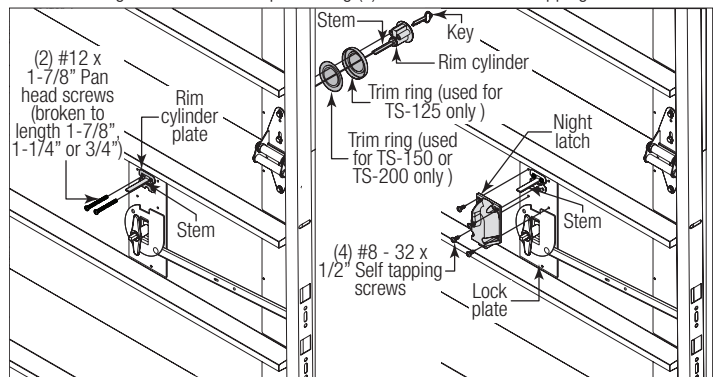

Attach spring to the lock bar and secure the spring to the lock section using (1) #12 x 1/2" screw. Slide the lock bar guide onto the lock bar. Level the lock bar and ensure the lock bar engages into the square hole in the vertical track. Once in position, secure the lock bar guide to the endcap using (2) 1/4" - 20 x 11/16" self drilling screws.

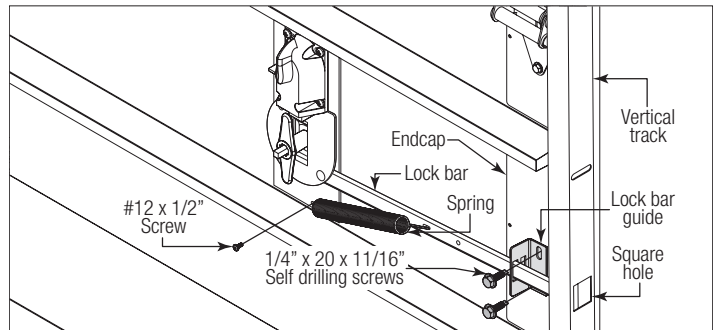

FOR DOUBLE LOCK BAR: On the left hand side, slide the lock bar guide(s) onto the lock bar.

NOTE: Depending on the width of the door, the left hand side may get two lock bar guides. Install one lock bar guide on the endcap and install the other lock bar guide in between the lock plate and the endcap.

NOTE: Ensure the lock bar engages the square hole in the vertical track before securing it to the section.

Level the lock bar and hold in position while securing the lock bar guide to the section using (2) 1/4" - 20 x 11/16" self drilling screws.

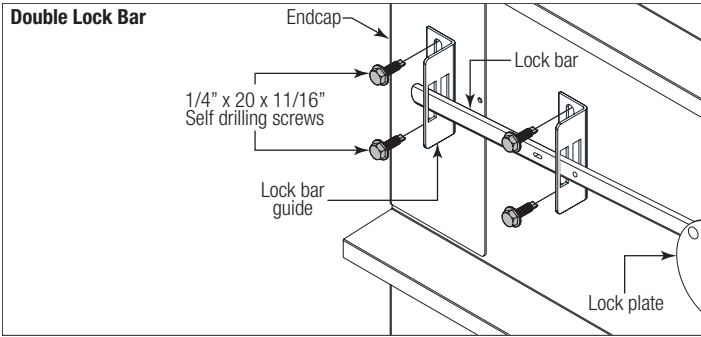

Step Plate

NOTE: Refer to Package Contents / Breakdown of Parts, to determine which step plate you have received and follow the corresponding illustrations below.

STEP PLATE (A): Locate the center of the bottom section of the door. On the inside of the door, center the outside step plate on the bottom section no higher than 6" from the bottom of the door.

IMPORTANT: DO NOT MOUNT THE STEP PLATE HIGHER THAN 6" FROM THE BOTTOM OF THE BOTTOM SECTION.

Using the step plate holes as a template, mark the hole location and pre-drill (2) 3/16" dia. holes through the face of the door.

NOTE: Drill through insulation and door's face on an insulated door.

CAUTION

BE CAREFUL TO KEEP DRILL STRAIGHT WHEN PRE-DRILLING. SECTION DAMAGE CAN RESULT FROM FAILURE TO KEEPING THE DRILL STRAIGHT.

On the outside of the door, enlarge the holes to 7/16" dia.

NOTE: Do not drill through or enlarge holes on the inside of the door.

Secure the outside step plate to the bottom using (2) #8 self-tapping screws. The #8 self-tapping screws varies with door models. Use the screw size shown below for your door model.

a) #8 x 3/4" self-tapping screws for model Thermospa[®] Model 125.

b) #8 x 1" self-tapping screws model Thermospa[®] Model 150.

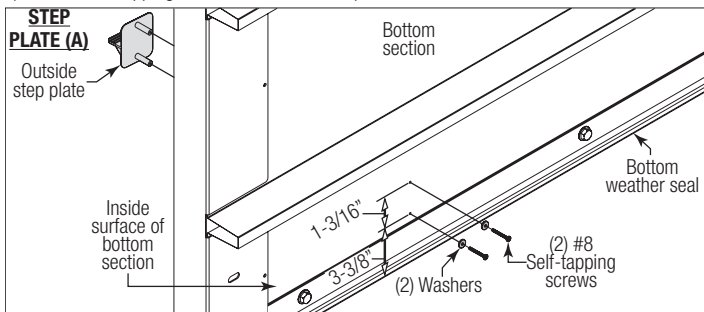

STEP PLATE (B): On the inside of the door, position the step plate in between the top and bottom ribs on the bottom section. Using the step plate holes as a template, mark the hole location onto the ribs of the bottom section and pre-drill (4) 3/16" dia. holes through the ribs of the bottom section.

CAUTION

BE CAREFUL TO KEEP DRILL STRAIGHT WHEN PRE-DRILLING. SECTION DAMAGE CAN RESULT FROM FAILURE TO KEEPING THE DRILL STRAIGHT.

Secure the step plate to the bottom section using (4) 1/4" - 20 carriage bolts and (4) 1/4" - 20 hex nuts, as shown.

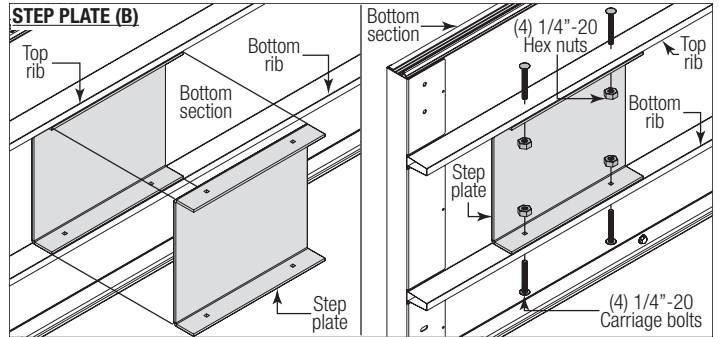

STEP PLATE (C): Install outside step plate in the pre-cut opening and bolt together with inside step plate using (2) 1/4" - 20 carriage bolts and (2) 1/4" - 20 nuts.

NOTE: If your door does not have the pre-cut opening you can cut a 7-5/8" wide by 3" high opening, 3" upward from the bottom edge of the bottom section. This will need to be in vertical alignment with your lock.

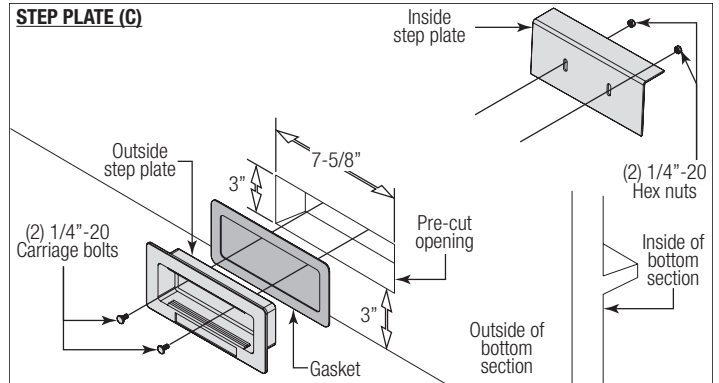

Pull Down Rope

WARNING

DO NOT INSTALL PULL DOWN ROPE ON DOORS WITH OPERATORS. CHILDREN MAY BECOME ENTANGLED IN THE ROPE CAUSING SEVERE OR FATAL INJURY.

Measure and mark the jamb approximately 48" to 50" (1220 to 1270 mm) from floor on the right or left side of jamb. Drill 1/8" pilot hole for no. 6 screw eye. Tie the pull down rope to the no. 6 screw eye and to the bottom corner bracket, as shown.

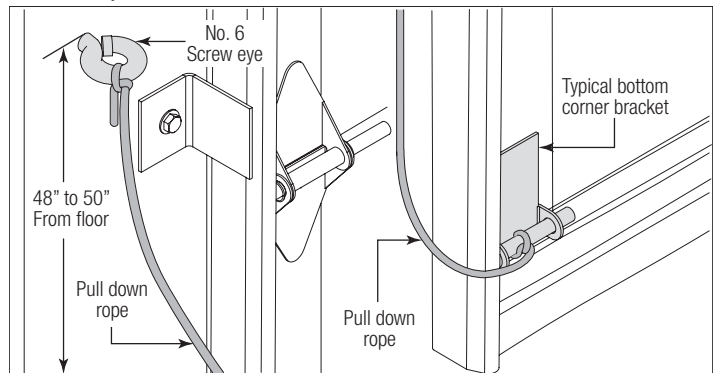

Exhaust Port

Using the illustrations below, locate and install the exhaust port assembly to the bottom section, using #10 counter sunk bolts and #10 hex nuts, as shown.

NOTE: The exhaust port goes on the inside of the bottom section.

NOTE: Prior to securing the exhaust port to the bottom section, field caulking is required. This is to prevent heavy frost and or condensation forming on the inside of the section.

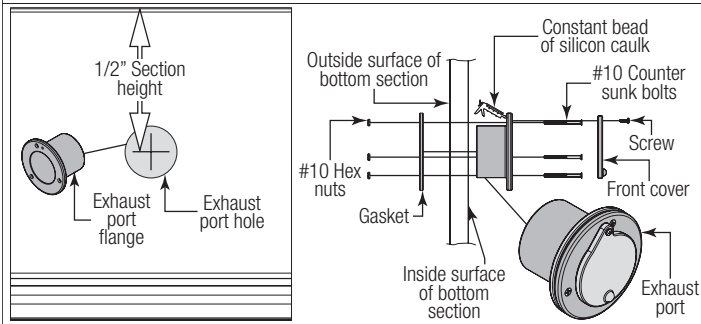

Chain Hoist

Chain Hoist Installation (Standard Lift Applications only!)

NOTE: Reference separate instructions for Chain Hoists and Jack Shaft Operators installation instruction.

CHAIN HOISTS AND JACK SHAFT OPERATORS ARE LIMITED TO:

- 1.) Standard Lift Doors with roof pitch track 2:12 or greater.
- 2.) High Lift track greater than or equal to 24".
- 3.) High Lift track 12" thru 24" with roof pitch track 1:12.

IMPORTANT: IF YOUR DOOR IS TO BE TROLLEY OPERATED, IT IS RECOMMENDED THAT AN OPTIONAL STRUT BE INSTALLED ON THE TOP SECTION.

⚠ WARNING

WAYNE DALTON RECOMMENDS THE USE OF A TROLLEY RAIL(S) AND AUXILIARY SHAFT FOR STANDARD OR HIGH LIFT DOORS BELOW THESE LIMITS. CABLE KEEPERS ARE RECOMMENDED FOR ALL CHAIN HOIST OR JACKSHAFTS OPERATORS. INSTALL THE CHAIN HOIST OR SPROCKET AS CLOSE TO THE END BEARING BRACKET AS POSSIBLE, TO MINIMIZE TORSION SHAFT DEFLECTION. CHAIN TENSIONERS ARE RECOMMENDED FOR DOORS OVER 144 SQ. FT. WITH JACKSHAFT OPERATORS.

⚠ WARNING

WAYNE DALTON RECOMMENDS THE USE OF A TROLLEY RAIL(S) COUPLED TO AN AUXILIARY SHAFT THAT IS POWERED BY A SIDE MOUNT TYPE CHAIN HOIST.

NOTE: 9" of extra headroom are required for these installations.

ASSEMBLE THE TROLLEY RAIL AS PER THE MANUFACTURES INSTALLATION INSTRUCTIONS.

NOTE: Back hang the trolley using angles, center hang supports are required for doors over 14' wide and 12' high.

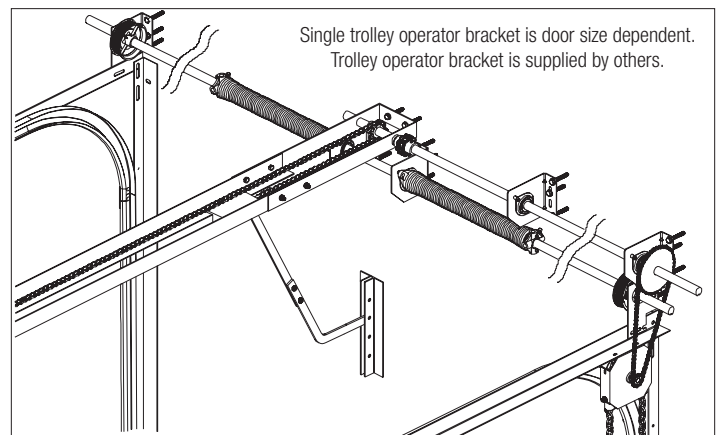
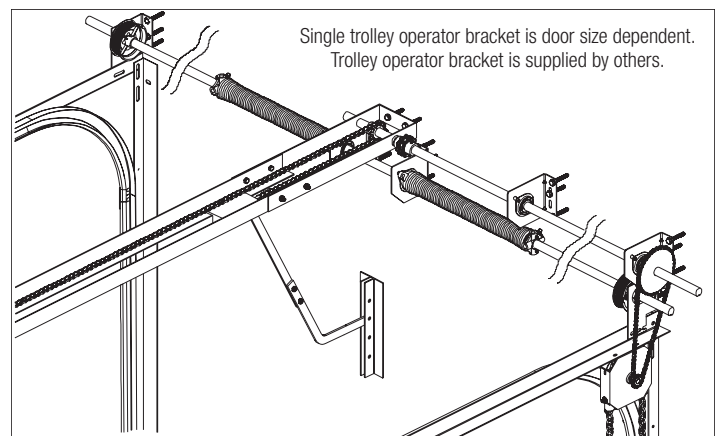
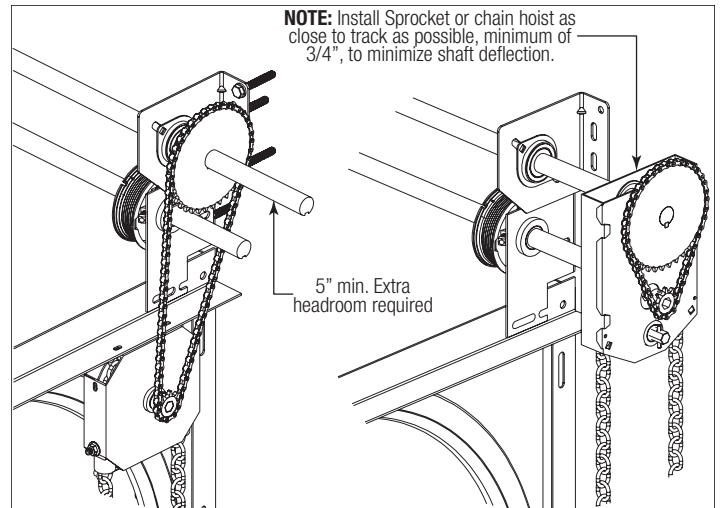
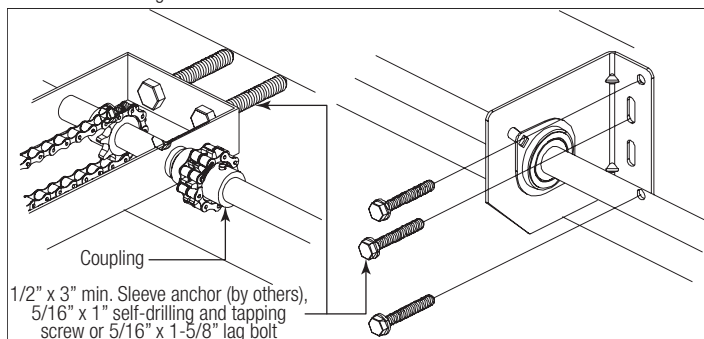

Pusher Springs

IMPORTANT: RIGHT AND LEFT HAND IS ALWAYS DETERMINED FROM INSIDE THE BUILDING LOOKING OUT.

Raise the door until bottom section is 3/4" below header. Starting on the left hand side, align the pusher spring with the top corner of the top section, as shown. Compress the pusher spring against the top fixture flange. Mark and drill (2) 3/8" dia. holes into the horizontal track. Secure the pusher spring bracket to the horizontal track using (2) 3/8" x 1-1/4" hex head bolts and nuts. Repeat same process for the right hand side.

NOTE: The (2) 3/8" x 1-1/4" hex head bolts may extend into the horizontal track.

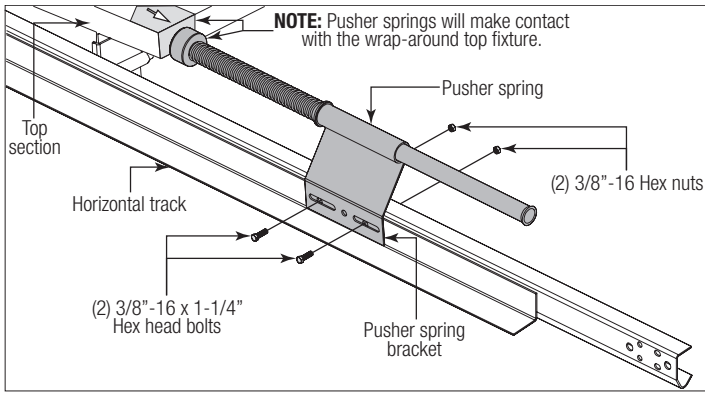

Cleaning Your Garage Door

IMPORTANT: DO NOT USE A PRESSURE WASHER ON YOUR GARAGE DOOR!

While factory-applied finishes on garage doors are durable, it is desirable to clean them on a routine basis. Some discoloration of the finish may occur when a door has been exposed to dirt-laden atmosphere for a period of time. Slight chalking may also occur as a result of direct exposure to sunlight.

Cleaning the door will generally restore the appearance of the finish. To maintain an aesthetically pleasing finish of the garage door, a periodic washing of the garage door is recommended.

THE FOLLOWING CLEANING SOLUTION IS RECOMMENDED:

A mild detergent solution consisting of one cup detergent (with less than 0.5% phosphate) dissolved into five gallons of warm water will aid in the removal of most dirt.

NOTE: The use of detergents containing greater than 0.5% phosphate is not recommended for use in general cleaning of garage doors.

NOTE: Be sure to clean behind weatherstrips on both sides and top of door.

CAUTION

NEVER MIX CLEANSERS OR DETERGENTS WITH BLEACH.

GLASS CLEANING INSTRUCTIONS

Clean with a mild detergent solution (same as above) and a soft cloth. After cleaning, rinse thoroughly.

ACRYLIC CLEANING INSTRUCTIONS

Clean acrylic glazing with nonabrasive soap or detergent and plenty of water. Use your bare hands to feel and dislodge any caked on particles. A soft, grit-free cloth, sponge or chamois may be used to wipe the surface. Do not use hard or rough cloths that will scratch the acrylic glazing. Dry glazing with a clean damp chamois.

NOTE: Do not use any window cleaning fluids, scouring compounds, gritty cloths or solvent-based cleaners of any kind.

Painting Your Garage Door

SURFACE PREPARATION FOR PAINTING

Wax on the surface must be removed or paint peeling/flaking will result. To remove this wax, it will be necessary to lightly scuff the surface with a fine steel wool pad saturated with soapy water. A final wipe and rinse should be done with clean water only to remove any loose particles and any soapy film residue.

Surface scratches, which have not exposed the metal substrate, can be lightly buffed or sanded with 0000 steel wool or no. 400 sand paper to create a smoother surface. Care must be taken to not expose the substrate under the paint. Once the substrate is exposed, the likelihood for rusting is greatly increased.

If substrate is exposed, it must be treated to prevent rust from forming. Sand the exposed area lightly and paint with a high quality metal primer specifically intended for galvanized surfaces to protect the area from corrosion. Allow for drying time on primer can label before applying topcoat.

The surface of the factory-applied finish, that is being painted, must not be too smooth, or the paint will not adhere to it. It is advisable to test in an inconspicuous area, to evaluate adhesion. If poor adhesion is observed, surface preparation for painting the factory-applied finish must be repeated until desired results are achieved. Again, care must be taken to not expose the substrate under the paint.

PAINTING:

After surface has been properly prepared, it must be allowed to dry thoroughly, and then coated immediately with premium quality latex house paint. Follow paint label directions explicitly. Oil base or solvent base paints are not recommended. Please note that if substrate is exposed and not properly primed, painting with latex paint may cause accelerated rusting of the steel in the exposed area.

NOTES:

1. Re-painting of finish painted steel doors cannot be warranted, as this condition is totally beyond the door manufacturer's control.
2. Consult a professional coatings contractor if in doubt about any of the above directions.
3. Follow directions explicitly on the paint container labels for proper applications of coatings and disposal of containers. Pay particular attention to acceptable weather and temperature conditions in which to paint.

Operation And Maintenance

OPERATING YOUR GARAGE DOOR:

Before you begin, read all warning labels affixed to the door and the installation instructions

and owner's manual. When correctly installed, your Wayne Dalton door will operate smoothly. Always operate your door with controlled movements. Do not slam your door or throw your door into the open position, this may cause damage to the door or its components. If your door has an electric opener, refer to the owner's manual to disconnect the opener before performing manual door operation below.

MANUAL DOOR OPERATION:

For additional information on manual garage door operations go to www.dasma.com and reference TDS 165.

IMPORTANT: DO NOT PLACE FINGERS OR HANDS INTO SECTION JOINTS WHEN OPENING AND/OR CLOSING A DOOR. ALWAYS USE LIFT HANDLES / SUITABLE GRIPPING POINTS WHEN OPERATING THE DOOR MANUALLY.

Opening a Door: Make sure the lock(s) are in the unlocked position. Lift the door by using the lift handles / suitable gripping points only. Door should open with little resistance.

Closing a Door: From inside the garage, pull door downward using lift handles / gripping points only or a high friction area only. If you are unable to reach the lift handles/ suitable gripping points only, use pull down rope affixed to the side of door. Door should close completely with little resistance.

USING AN ELECTRIC OPERATOR:

IMPORTANT: PULL DOWN ROPES MUST BE REMOVED AND LOCKS MUST BE REMOVED OR MADE INOPERATIVE IN THE UNLOCKED POSITION.

When connecting a drawbar (trolley type) garage door operator to this door, a drawbar operator and/or drawbar operator bracket must be securely attached to the top section of the door, along with any struts provided with the door. Always use the drawbar operator and/or drawbar operator bracket supplied with the door. To avoid possible damage to your door, Wayne Dalton recommends reinforcing the top section with a strut (may or may not be supplied). The installation of the drawbar operator must be according to manufacturer's instructions and force settings must be adjusted properly. Refer to the owner's manual supplied with your drawbar operator for complete details on installation, operation, maintenance and testing of the operator.

MAINTAINING YOUR GARAGE DOOR:

Before you begin, read all warning labels affixed to the door and the installation instructions and owner's manual. Perform routine maintenance steps once a month, and have the door professionally inspected once a year. Review your Installation Instructions and Owner's Manual for the garage door. These instructions are available at no charge from Wayne Dalton, a division of Overhead Door Corporation, P.O. Box 67, Mt. Hope, OH., 44660, or at www.Wayne-Dalton.com. For additional information on garage door/operator maintenance go to www.dasma.com and reference TDS 151, 167 and 179.

MONTHLY INSPECTIONS:

1. Visual Inspection: Closely inspect jambs, header and mounting surface. Any wood found not to be structurally sound must be replaced. Inspect the springs, counterbalance lift cables, track rollers, pulleys, rear back hangs and other door hardware for signs of worn or broken parts. Tighten any loose screws and/or bolts. Check exterior surface of the door sections for any minor cracks. Verify door has not shifted right or left in the opening. If you suspect problems, have a trained door system technician make the repairs.

WARNING

GARAGE DOOR SPRINGS, COUNTERBALANCE LIFT CABLES, BRACKETS, AND OTHER HARDWARE ATTACHED TO THE SPRINGS ARE UNDER EXTREME TENSION, AND IF HANDLED IMPROPERLY, CAN CAUSE SEVERE OR FATAL INJURY. ONLY A TRAINED DOOR SYSTEMS TECHNICIAN SHOULD ADJUST THEM, BY CAREFULLY FOLLOWING THE MANUFACTURER'S INSTRUCTIONS.

WARNING

NEVER REMOVE, ADJUST, OR LOOSEN THE BOLTS, SCREWS AND/OR LAG SCREWS ON THE COUNTERBALANCE (END OR CENTER BEARING BRACKETS) SYSTEM OR BOTTOM CORNER BRACKETS OF THE DOOR. THESE BRACKETS ARE CONNECTED TO THE SPRING(S) AND ARE UNDER EXTREME TENSION. TO AVOID POSSIBLE SEVERE OR FATAL INJURY, HAVE ANY SUCH WORK PERFORMED BY A TRAINED DOOR SYSTEMS TECHNICIAN USING PROPER TOOLS AND INSTRUCTIONS.

TORSION SPRINGS: The torsion springs (located above the door) should only be adjusted by a trained door systems technician. DO NOT attempt to repair or adjust torsion springs yourself.

EXTENSION SPRINGS: A restraining cable or other device should be installed on the extension spring (located above the horizontal tracks) to help contain the spring if it breaks.

2. Door Balance: Periodically test the balance of your door. If you have a garage door drawbar operator, use the release mechanism so you can operate the door by hand when doing this test. Start with the door in the fully closed position. Lift the door to check its balance. Adjust Extension spring(s), if door lifts by itself (hard to pull down) or if door is difficult to lift (easy to pull down). DO NOT attempt to repair or adjust Torsion Springs yourself. To adjust Extension spring(s), refer to your installation instructions and owner's manual. If in question about any of the procedures, do not perform the work. Instead, have it adjusted by a trained

door systems technician.

3. Lubrication: The door should open and close smoothly. Ensure the door track rollers are rotating freely when opening and closing the door. If track rollers do not rotate freely, clean the door tracks, removing dirt and any foreign substances. Clean and lubricate (use a non-silicon based lubricant) graduated end hinges, center hinge(s), steel track rollers, bearings and torsion spring(s) (torsion spring coil surfaces). DO NOT lubricate plastic idler bearings, nylon track rollers, door track. DO NOT oil a cylinder lock, if actuation is difficult use a graphite dust to lubricate.

Limited Warranty

Thermospan® Models 200-20, 200, 150 and 125

Wayne Dalton, a division of Overhead Door Corporation ("Seller") warrants to the original purchaser of the Thermospan® Models 200-20, 200, 150 or 125 Commercial Sectional Door ("Product"), subject to all of the terms and conditions hereof, that the Product and all components thereof will be free from defects in materials and workmanship for the following period(s) of time, measured from the date of installation:

- **TEN (10) YEARS** against cracking, splitting, rust deterioration and delamination on Thermospan® Models 200-20, 200 and 150.
- **EIGHT (8) YEARS** against cracking, splitting, rust deterioration and delamination on Thermospan® Model 125
- **ONE (1) YEAR** against defects in materials and workmanship

Seller's obligation under this warranty is specifically limited to repairing or replacing, at its option, any part which is determined by Seller to be defective during the applicable warranty period. Any labor charges are excluded and will be the responsibility of the purchaser.

This warranty is made to the original purchaser of the Product only, and is not transferable or assignable. This warranty does not apply to any unauthorized alteration or repair of the Product, or to any Product or component which has been damaged or deteriorated due to misuse, neglect, accident, failure to provide necessary maintenance, normal wear and tear, acts of God, or any other cause beyond the reasonable control of Seller or as a result of having been exposed to toxic or abrasive environments, including blowing sand, salt water, salt spray and toxic chemicals and fumes.

THIS WARRANTY IS EXCLUSIVE AND IN LIEU OF ANY OTHER WARRANTIES, EITHER EXPRESSED OR IMPLIED, INCLUDING BUT NOT LIMITED TO ANY IMPLIED WARRANTY OF MERCHANTABILITY OR FITNESS FOR A PARTICULAR PURPOSE.

IN NO EVENT SHALL SELLER BE RESPONSIBLE FOR, OR LIABLE TO ANYONE FOR, SPECIAL, INDIRECT, COLLATERAL, PUNITIVE, INCIDENTAL OR CONSEQUENTIAL DAMAGES, even if Seller has been advised of the possibility of such damages. Such excluded damages include, but are not limited to, loss of use, cost of any substitute product, or other similar indirect financial loss.

Claims under this warranty must be made promptly after discovery, within the applicable warranty period, and in writing to the authorized dealer or installer whose name and address appear below. The purchaser must allow Seller a reasonable opportunity to inspect any Product claimed to be defective prior to removal or any alteration of its condition. Proof of the purchase and/or installation date, and identification as the original purchaser, may be required.

• SELLER: _____

• SELLER'S ADDRESS: _____

Thank you for your purchase.

If you need assistance, please call 1-866-569-3799 (press Option 1) and follow the prompts to contact a customer service representative. They will be happy to handle any questions that you may have.

After installation is complete, leave this Installation Instructions And Owner's Manual with the homeowner, or fasten it near garage door for easy reference.